

# EOCR-DM2 Series

Basic model : EOCR-3DM2 (Z) / FDM2 (Z)



## General features

- Micro-controller unit based
- Real time processing / High precision
- Protections : Over current, Under current, Phase loss, Phase reversal, Stall, Jam, Current Imbalance, Earth fault (**3MZ2/FMZ2**)
- Inverse available up to 32Amps without external CTs.
- Ancillary functions : Fail safe, Pre-alarm (**3DM2/FDM2**), Accumulated running hour, 3 faults records & limitation of auto-restart.
- Reinforced monitoring function : Monitoring distance up to 400M, 3 phase current display, Pre-alarm (**3DM2/FDM2**) & Trip cause indication
- Bar graph indication of a load current to the current setting.
- Available application on single and 3 phase motor
- RoHS Compliance
- For **FDM2/FMZ2**, normal protections are guaranteed even if PDM is disconnected.

# EOCR-DM2 Series

Basic model : EOCR-3DM2 (Z) / FDM2 (Z)

## Protection functions

Protection item	Condition & Setting range	Operation time
<b>Over current (oc)</b>	Condition : Load current (In) exceeds setting current (Is) Setting range : 0.5~60A (Def), 0.5~32A (Inv)	Definite (Def) : 0.2~30s adjust. Inverse (Inv) : 1~30 class
<b>Under current (uc)</b>	Condition : Load current (In) less than setting current $In \leq uc$ uc should be less than oc setting	oFF, 1~10s adjustable
<b>Phase loss (PL)</b>	Condition : max imbalance is more than 85% among 3 phase current, Enable or disable : Selectable	oFF, 0.5~5s adjustable
<b>Reverse phase (RP)</b>	Condition : Reversed phase sequence input on EOCR. Enable or disable : Selectable	Within 0.15s
<b>Stall (Sc)</b>	Condition : $In \geq$ Stall current setting (Sc). Active only in motor starting 0.5~30A : 2~8 times of oc setting ~40A : 2~6 times, ~60A : 2~4 times.	Right after D-time elapsed
<b>Jam (JA)</b>	Condition : $In \geq$ Jam current setting (JA). Active only in motor running 0.5~50A : 1.5~5 times of oc setting ~60A : 1.5~4 times of oc setting	0.3~5s adjustable
<b>Imbalance (IM)</b>	Condition : Current imbalance $\geq$ Setting imbalance % Setting range : 10~50% of imbalance	1~10s adjustable
<b>Earth fault (EF)</b>	Condition : EF current (Ie) exceeds setting current (Ies) OFF, 0.03~10A	0.05~5s adjustable -- 3M22/FM22 only --

## Ancillary functions

<b>Password selection</b>	For secured setting parameters.
<b>Phase selection</b>	For single phase / three phase motor selection
<b>TCC selection</b>	Available three time-current-characteristics ( Definite, Inverse, Thermal inverse)
<b>CT ratio</b>	For the current setting more than 60A (20A : <b>i3MS/FMS</b> ) and less than 0.5A
<b>Fail safe selection</b>	Fail safe operation for OL trip output.
<b>Pre alarm selection</b>	Pre alarm signaling by the 07-08 output contact
<b>Total running hour</b>	Total accumulated running hour from the installation which cannot be modified and reset.
<b>Running hour</b>	Display or provide a time-out signal to the 07-08 output contact. ( <b>i3DM/FDM</b> )
<b>Reset mode</b>	Manual / Auto / Electrical ; Selectable
<b>Trip cause memory</b>	Store the latest 3 trip causes
<b>Restart limitation</b>	The maximum auto-restart number within 30 minutes in auto-reset mode.

# EOCR-DM2 Series

Basic model : EOCR-3DM2 (Z) / FDM2 (Z)

## Specifications

Model		3DM2 / FDM2, 3MZ2 / FMZ2	
Over current	Rated setting range (A)	Definite TCC : 0.5~60A : use external CT higher than 60A	
		Inverse TCC : 0.5~60A : use external CT higher than 32A	
Under current	Rated setting range (A)	0.5A ~ less than oc setting	
Operating time characteristics		Definite(Def) / Inverse(Inv)	
Time setting	Def	D-time	0~200s
		O-time	0.2~30s
	Inv (cLS)	1~30 classes	
	GF delay time (Edt)	0~30s	(3MZ2/FMZ2)
	GF O-time (Et)	0.05~10s	(3MZ2/FMZ2)
	Auto-reset	0.5s~20min.	
	Reset mode	Manual reset (H-r) / Electric reset (E-r) / Auto-reset (A-r)	
Control power	Voltage	100~240VAC/DC (85% ~110%, Free voltage), 24VAC/DC (±5%) .	
	Frequency	50/60Hz	
	Power consumption	Lower than 7VA	
Output	Capacity	3A/250VAC resistive.	
	Composition	1a1b : OC or GR 1a : AL	
Display	7 segment LED	3 phase amps, Cause of trip, Setting parameters indication.	
	Bar-graph	Load factor.	
Mounting	Panel mounting (3DM2/3MZ2)		
	Flush mounting (FDM2/FMZ2)		
Insulation	Between case & circuit	Over DC500V 10MΩ	
Dielectric strength	Between case & circuit	2kV, 50/60Hz, 1 Min.	
	Between contacts	1kV, 50/60Hz, 1 Min.	
	Between circuit	2kV, 50/60Hz, 1 Min	
Electrostatic discharge (ESD)	IEC61000-4-2	Level 3 : Air discharge : ±8kV, Contact discharge : ±6kV	
Radiated disturbance	IEC61000-4-3	Level 3 : 10V/m, 80 ~ 1000MHz	
Conducted disturbance	IEC61000-4-6	Level 3 : 10V, 0.15 ~ 80MHz	
EFT/Burst	IEC61000-4-4	Level 3 : ±2kV, 1 Min.	
Surge	IEC61000-4-5	Level 3 : 1.2 x 50μs, ±4kV (0°, 90°, 180°, 270°)	
Emission	CISPR11	Class A ( Conducted and radiated)	
Environment	Temperature	Store	-40°C ~ +85°C
		Operation	-20°C ~ +60°C
	Humidity	30~85% RH (Non-condensate)	
Dimension	Window type	70W × 74.5H × 83.8D	
	Bottom hole type	70W × 56.3H × 108.1D	
Weight		<b>3DM2 / 3MZ2</b>	<b>FDM2 / FMZ2</b>
	Window type	265g	350g
	Bottom hole type	295g	390g
	Terminal type	295 + 120 = 415g	390 + 120 = 510g
	Display (W/3M cable)		125g
Power consumption		Less than 7VA.	

# EOCR-DM2 Series

Basic model : EOCR-3DM2 (Z) / FDM2 (Z)

## Front face

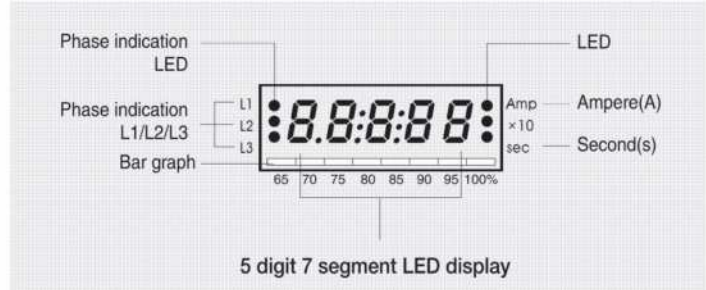
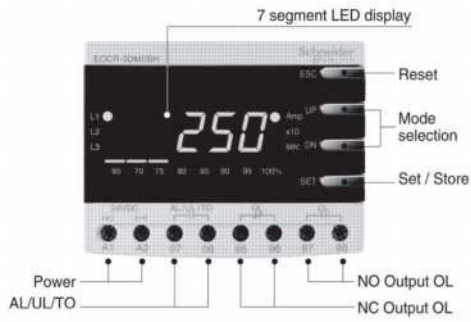

3 phase currents (In) and a leakage current (3MZZ/FMZZ) are displayed every 2 seconds in sequence.

### Bar graph

- it shows the load factor to OC setting value by %
- % value = (running current/setting current) \* 100%
- Min scale is 65%
- if the setting value is the rated motor current, it shows the load factor of the motor.

### Current display

- Shows the highest current among three phases for OC, Stall, Jam trips.
- Shows the lowest current among three phases for UC, UB
- Shows the lost phase for PL.
- Shows the phase and the current during running.

Amp : Ampere. LED is on when a current display.

x 10 : Shows the unit changed to 10 times.

Sec : Second. LED is on when a time display.

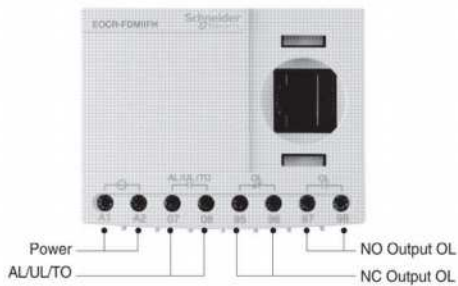

# EOCR-DM2 Series

Basic model : EOCR-3DM2 (Z) / FDM2 (Z)

## 3 phase digital ammeter function

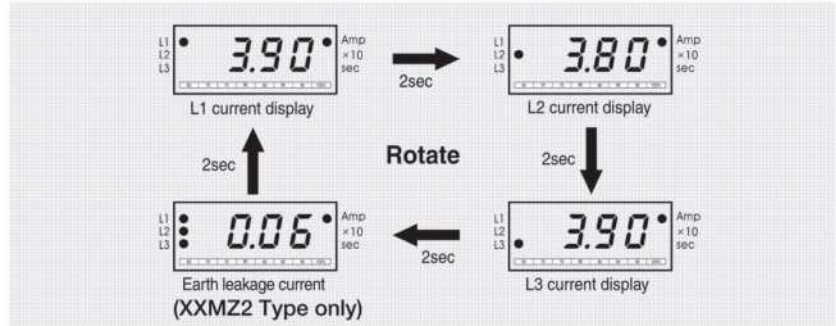

- \* Blocking display rotation can be done by pressing the SET button once during running. whenever press the SET button, the each phase current displays by turns. A fixed phase current display can be done by this.
- \* Pressing the ESC button, it returns to the Auto current display rotation mode.

## Buttons and Setting Sequence

Button	Description
▲ UP / ▼ DN	Navigate menus by pressing UP/DN button.
SET	Select a parameter to change, then the parameter starts blinking.
▲ UP / ▼ DN	Modify a parameter value by pressing UP/DN button.
SET	Memorize the values in the relay by pressing SET button. blinking stops to show it's stored.
ESC	Pressing ESC button, it returns to the current display. Without pressing ESC button, it returns to the load current display in 50sec automatically.

- \* Fault history check : Pressing the ESC button more than 5sec, it displays the latest fault cause and the fault current or fault phase. Continuing to press DN button, you can see the current of L1(R), L2(S), L3(T), (GR) in turn. press the DN button again to check the previous fault continually. In the latest fault display, the 100% LED of bar graph lights on and two LEDs of 95%, 100% lights on for the second fault display, three LEDs of 90%, 95%, 100% lights on for the oldest fault display. When you press the ECS button in this mode, it returns to the normal current display mode. The oldest fault record is over written when the number of fault to record exceeds three.

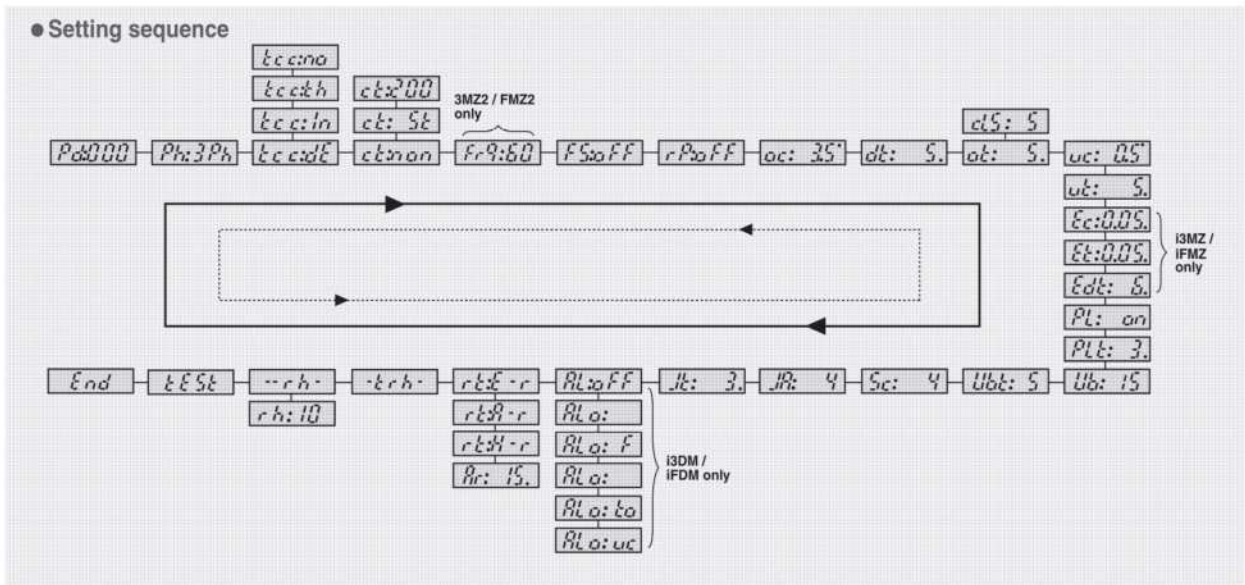

# EOCR-DM2 Series

Basic model : EOCR-3DM2 (Z) / FDM2 (Z)

## Setting sequence and menu

No.	Menu	Parameter	Description	Default
1	Selection of phase No.	Ph: 3Ph Ph: 1Ph	"Ph:3Ph" mode for a 3 phase load, "Ph:1Ph" mode for a 1 phase load should be selected. If you select the "Ph:1Ph", RP, PL and Ub functions will be disabled and not displayed in the menu mode	Ph: 3Ph
2	Operation curve	tcc:dE tcc:In tcc:th tcc:no	Time-current characteristic(TCC) setting. "dE" is for definite TCC, "In" is for inverse TCC, "th" is for thermal inverse TCC. Refer to the time-current characteristic curve. If tcc=no, only overcurrent protection is disabled	tcc:dE
3	CT ratio	ct:non ct:200 ct:2t ct:800 ct:5t	External CT ratio setting mode. This is applied to definite TCC: higher than 60A and Inverse TCC: higher than 30A. Set the primary value of the external CT. For example, 200:5 CT, setting is "ct:200". For the low-range current "ct:2t" is for (2 loops), "ct:5t" is for (5 loops). Select "ct: non" in case of no external CT and single loop.	ct:non
4 #1	Frequency	Fr 9.60 Fr 9.50	Frequency setting mode. Select 50 or 60 based on the system fundamental frequency.	Fr 9.60
5	Fail safe	FS: on FS:off	Selection of fail safe(No volt release) mode for overload trip output, OL. Refer to fail-safe operation	FS:off
6	Reversed phase detection	rP: on rP:off	Enable or disable reverse phase detection	rP:off
7	Over current threshold	oc: 3.5	Threshold for over current protection. this value cannot be set below a under current threshold (uc).	oc: 3.5
8	Start delay time	dt: 5	Motor starting delay, OC, UC, Stall, Jam, Ub are blocked during starting but PL, RP are not blocked. For "In" TCC mode, the cold curve is applied before dt expires and, the hot curve is applied after the dt expires.	dt: 5
9	Over current duration (Trip delay time / Trip class)	ot: 5	(tcc:dE) : the fault(over current) duration of definite overcurrent protection. (tcc:In) : the trip class for inverse overcurrent protection (refer to TCC curve) (tcc:th) : the thermal overload protection based on the thermal image by load current (refer to TCC curve).	ot: 5
10	Under current threshold	uc: 0.5	Threshold for under current protection. The setting should be higher than no-load current of a motor. The current value cannot be set higher than OC.	uc: 0.5
11	Under current duration (Trip delay time)	ut: 5	Fault (under current) duration for the under current operation. If the setting of "oFF" in the "uc" mode is selected, this menu is not displayed	ut: 5
12 #1	Earth fault (Ground fault) threshold	Ec:0.05	Threshold for earth fault protection. The capacitance leakage current of the motor and cable should be taken into account for the setting. The threshold value corresponds to the primary current of ZCT	Ec: 0.5
13 #1	Earth fault trip delay time	Et:0.05	Earth fault duration (Trip delay time) TCC is definite characteristic	Et:1
14 #1	EF starting delay	Edt: 6	Blocking time of earth fault detection during motor starting. OFF, 1~30s adjustable this timer is only active during motor starting.	Edt: 0
15	Phase loss	PL: on PL:off	Enable or disable Phase Loss(Single Phasing) detection. If the "Ph:1Ph" is selected, this menu is not displayed.	PL: on
16	Phase loss time	PLt: 3	Fault duration for phase loss operation. The setting range is 0.5~5 sec. if "PL: oFF" is selected, this menu is not displayed.	PLt: 3
17	Imbalance threshold	Ub: 15	Threshold for current imbalance operation. To disable the function, set to "oFF", the setting range is 10~50%. Imbalance factor (%) = $(I_{max\_phase} - I_{min\_phase}) / I_{max\_phase} \times 100\%$ Imbalance fault duration (trip delay time) for current imbalance operation. The setting range is 1~10 seconds.	Ub: 15
18	Imbalance fault duration	Ubt: 5	Threshold for locked rotor detection during motor starting. The value is the multiples of the over current threshold(oc). If the locked rotor condition is detected, the trip relay operates in 0.5s after the "dt" expires. If dt=0, this function is disabled and not displayed in the menu.	Ubt: 5
19	Stall threshold	Sc: 4	Setting range : oc=0.4~30A : 2~8times, oc < 40A : 2~6times, otherwise (oc<60A) : 2~4times, (with Ext. CT : ?)	Sc: 4
20	Jam threshold	JR: 4	Threshold for locked rotor detection during motor running. The value is the multiples of the over current threshold (oc). Setting : oc=0.4~50A : 1.5~5times, otherwise (oc<60A) : 4times, (with Ext. CT : ?)	JR: 4

# EOCR-DM2 Series

Basic model : EOCR-3DM2 (Z) / FDM2 (Z)

## Setting sequence and menu

No.	Menu	Parameter	Description	Default
21	Jam fault duration	jt: 3.	Jam fault duration (trip delay time) Setting : 0.2-10 sec	jt: 3.
22 #2	Alert	AL: 85 AL: oFF	Threshold of alert output, set by % of the over current threshold (oc). If the load current is higher than this value, alert output(07-08 contact) is energized according to the setting of "ALo:XX".	AL: oFF
		ALo: A	If the load current is detected, alert output(07-08 contact) is energized. The alert threshold is no meaning for this operation. Refer to the alert operation pattern.	
		ALo: F	If the load current is higher than the alert threshold, alert output(07-08 contact) repeats open for 1s and close for 1s (flickering). The flickering starts from the motor starting. Refer to the alert operation pattern.	
		ALo: H	If the load current is higher than the alert threshold, alert output(07-08 contact) is closed (holding) and remains closed until the load current decrease under the alert threshold. The alert output is blocked during motor starting. Refer to the alert operation pattern.	
		ALo: to	If the accumulated running hour is more than the running hour threshold, the alert output repeats close for 1s and open for 1s.	
		ALo: uc	The alert output is used only for under current protection. If this mode is selected, a trip by an under current fault is signaled through alert output(07-08), instead of overload trip output(95-96 or 97-98).	
23	Reset	rt: E-r	Fault reset (electrical reset) by a power cycle or by pressing the ESC button.	rt: E-r
		rt: H-r	Fault reset (hand reset) by only pressing the ESC button.	
		rt: A-r Ar: 15.	Fault reset (auto reset) by a auto-reset timer, Setting range of the timer : 0.5sec-20min.	
		Ar: 20n	Also the fault can be reset by power cycle or by ESC button.	
24	Restart limitation	rn: 3	The maximum auto-restart number during 30 minutes in auto-reset mode. The auto-restart counter (count) is stored in the non-volatile memory and is cleared by pressing ESC button when the counter (count) reaches the limitation. To disable limitation, select "oFF". Setting range : oFF-5 times.	rn: oFF
25	Total running hour	-trh- 033	In this menu, toggle display, "-trh-" and the accumulated (time) value, is activated (?) The accumulation starts from the installation and the user cannot clear the accumulated value. This display unit is 1 hour.	read only
26	Running hour	--rh- 43.3	In this menu, toggle display, "--rh-" and the accumulated value, is activated (?) The user can clear the accumulated value by selecting the running hour threshold to "rh : oFF". This display unit is 0.1 hour (6 minutes). By selecting "ALo : to", the user can get the alert signal through alert output (07-08) when the accumulated value is more than the running hour threshold.	read only
	Running hour threshold	rh: 10.	Threshold for alert output when the user selects "ALo : to". The unit is 10 hours and this menu is not displayed when the motor is starting or running. Setting range : 10-9990 hours, oFF	
27	Test trip	tEst	When this menu activated, OL trip signal and enabled short or EF trip signal is generated when (3s+ot) expires. The display shows "End" when the test is done. By pressing ESC, returns to the load current display mode. This menu is not displayed when the motor is starting or running. Before (3s+ot) expires, pressing ESC or motor starting or running blocks the test trip and return to the load current display. No parameter	No parameter
28	End	End	This shows the end of test trip. Test result is stored in the fault record.	No parameter

\* #1 => These are applied to 3M22 & FM22 only.

\* #2 => These are applied to 3DM2 & FDM2 only.

# EOCR-DM2 Series

Basic model : EOCR-3DM2 (Z) / FDM2 (Z)

## Alert operation pattern (3DM2 & FDM2 only)

ALO selection	Running stage	Starting	Normal operation	Higher than the preset alert value	Trip
Aux (RLo: A)					
Flicker (RLo: F)					
Hold (RLo: H)					

- ALO "A" : Ampere relay function (The 07-08 output contact is closed when a current is detected)
- ALO "F" : Flickering (When a current flows, the output contact is closed and repeating the close and open on it in a higher current than the AL setting.)
- ALO "H" : Holding (The output contact is closed in a higher current than the AL setting.)
- ALO "uc" : Applied to "uc" (under current protection) output contact.
- ALO "to" : When a running hour time is elapsed over the "rh" set value, the output contact repeats the close - open.

## Fail-safe operation

Fail-Safe	A1-A2 not powered	A1-A2 powered and under normal operation	A1-A2 powered and Tripped
ON	95  96 Close 97  98 Open	95  96 Open 97  98 Close	95  96 Close 97  98 Open
OFF	95  96 Close 97  98 Open	95  96 Close 97  98 Open	95  96 Open 97  98 Close

## Trip cause indication and fault records

3 fault records including the trip cause and 3phase currents are stored in a non-volatile memory. When the motor is running or stopped, trip cause can be navigated by pressing ESC button over 5seconds

Trip indication					
Trip cause	Trip		Indication after trip with UP/ DN button pressing		
	Indication	Contents of indication	L1 LED on	L2 LED on	L3 LED on
Over current		OC Trip caused by r(L1)-phase current			
Phase loss		Phase loss caused by r(L1)-phase lost			
Reversed phase		Phase reversal trip			
Stall		Stall trip during motor starting caused by s(L2)-phase current			
Jam		Jam trip during motor running caused by t(L3)-phase current			
Imbalance		Imbalance trip caused by t(L3)-phase current			
Under current		Under current trip caused by s(L2)-phase current			
Earth fault (3M2/FM2)		Earth fault(Earth leakage) trip with Earth fault current indication			
Limitation of auto-restart		In 30minutes, the number of auto-restart by auto-reset exceeds the setting	For emergency restart, manual reset by pressing ESC clears the restart counter to zero.		

# EOCR-DM2 Series

Basic model : EOCR-3DM2 (Z) / FDM2 (Z)

## Time-current characteristic curve

### Definite characteristic

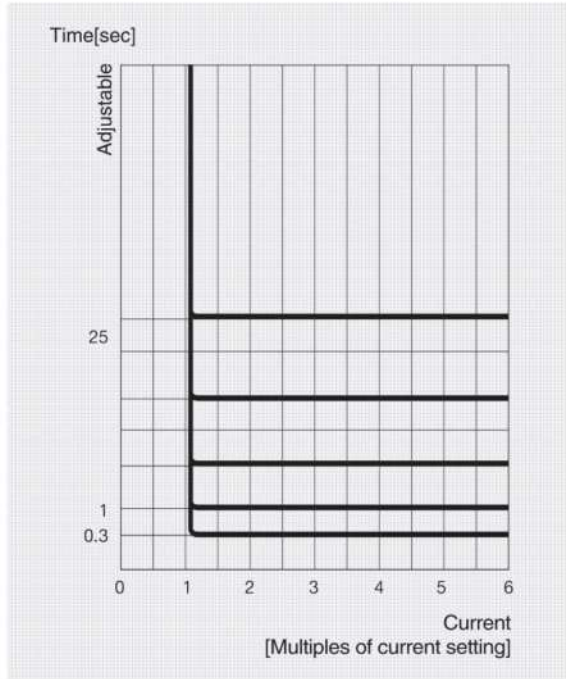

### Inverse characteristic

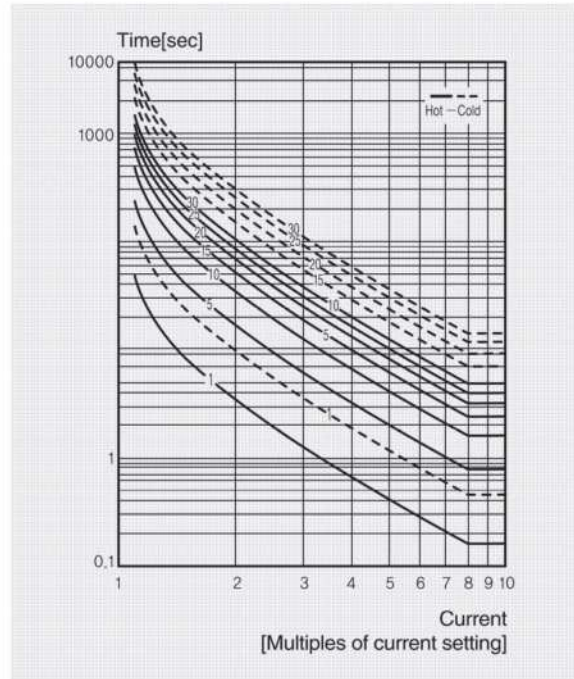

## Current setting range

Setting range	Number of pass through the CT hole	External CT ratio	CT setting	Remark
0.5 ~ 60A	1	No CT combination	ct:non	
0.25 ~ 3A	2	No CT combination	ct: 2t	
0.1 ~ 1.2A	5	No CT combination	ct: 5t	
0.5 ~ 32A	1	No CT combination	ct:non	Inverse TCC
0.5 ~ 60A	1	No CT combination	ct:non	Definite TCC
10 ~ 100A	1	100 : 5	ct:100	Definite or inverse
20 ~ 200A	1	200 : 5	ct:200	Definite or inverse
30 ~ 300A	1	300 : 5	ct:300	Definite or inverse
40 ~ 400A	1	400 : 5	ct:400	Definite or inverse
50 ~ 500A	1	500 : 5	ct:500	Definite or inverse
60 ~ 600A	1	600 : 5	ct:600	Definite or inverse
70 ~ 700A	1	700 : 5	ct:700	Definite or inverse
80 ~ 800A	1	800 : 5	ct:800	Definite or inverse

# EOCR-DM2 Series

Basic model : EOCR-3DM2 (Z) / FDM2 (Z)

## Typical wiring schematic (EOCR-3DM2/FDM2)

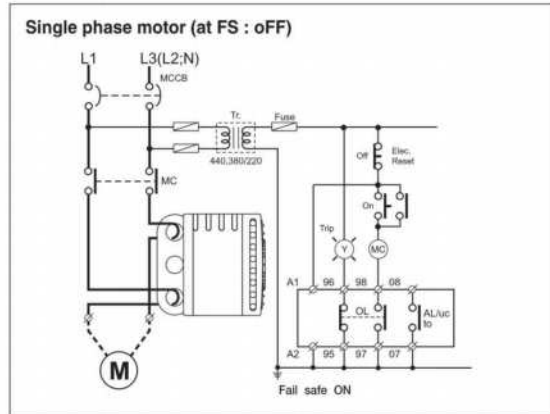
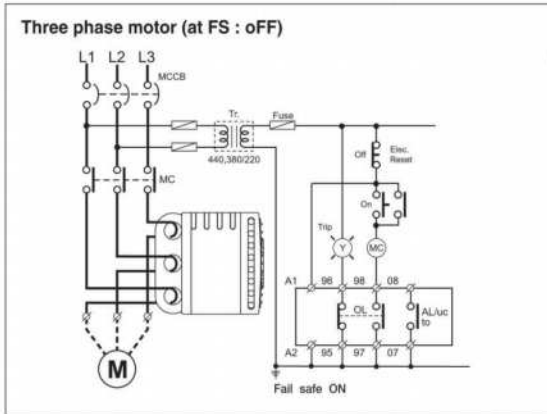
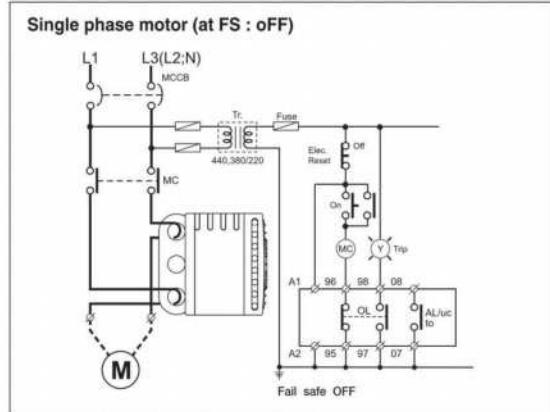
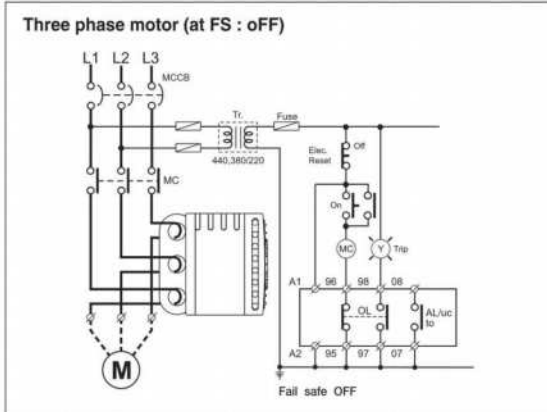

## Typical wiring schematic (EOCR-3M2Z/FM2Z)

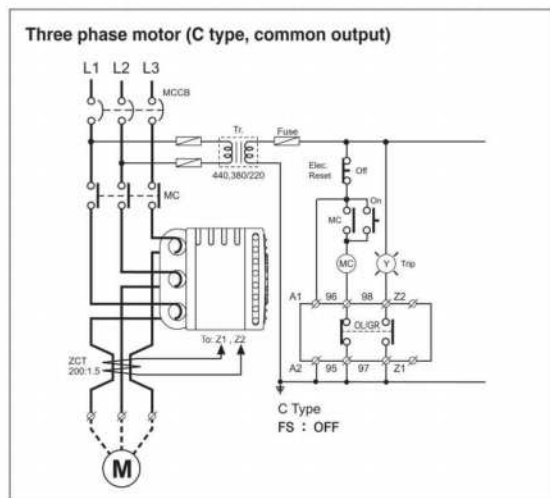
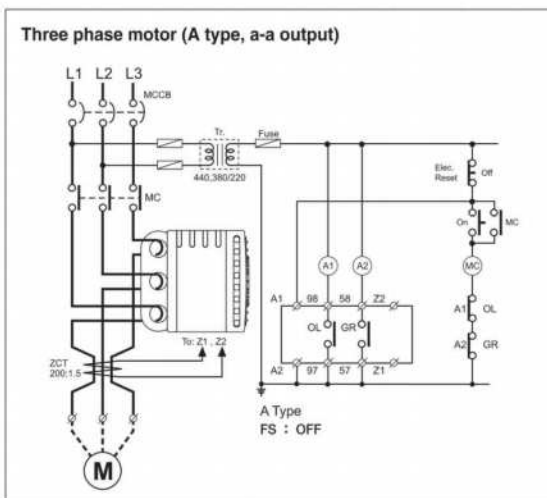

# EOCR-DM2 Series

Basic model : EOCR-3DM2 (Z) / FDM2 (Z)

## Typical wiring schematic (EOCR-3M2Z/FM2Z)

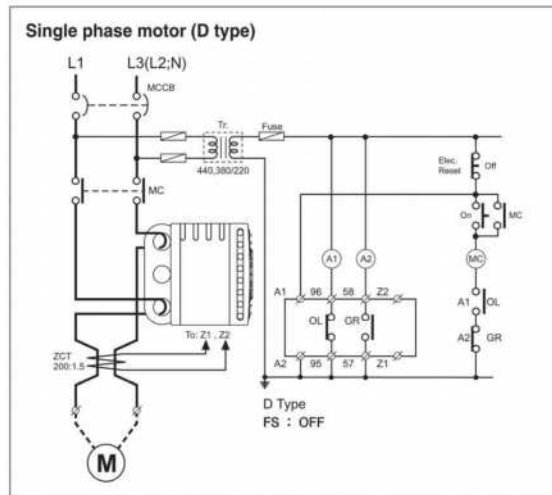
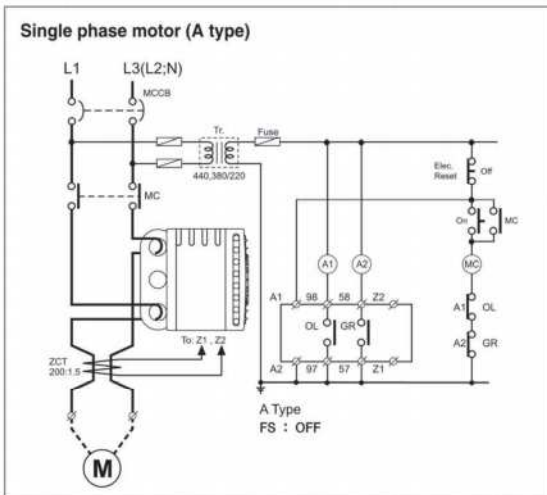
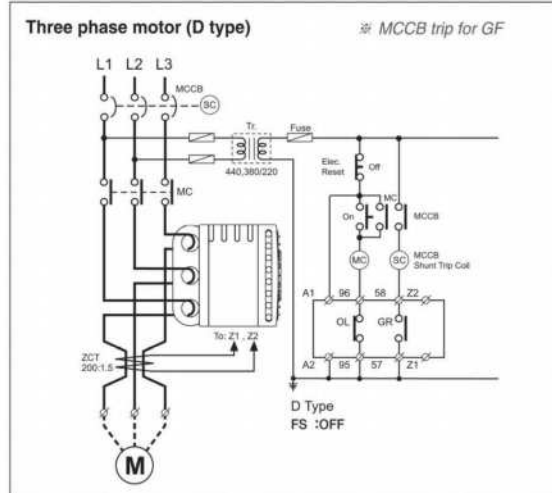
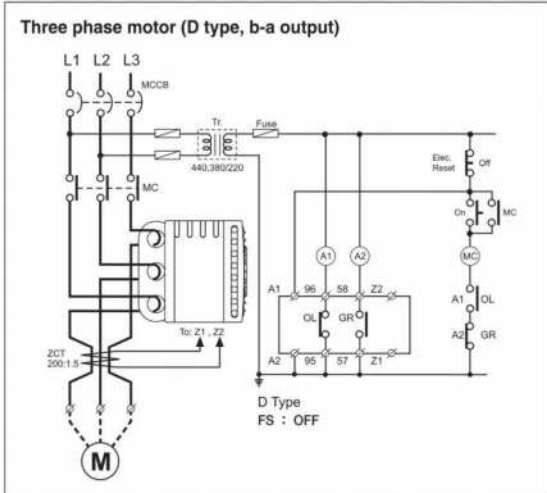

# EOCR-DM2 Series

Basic model : EOCR-3DM2 (Z) / FDM2 (Z)

## Control terminals

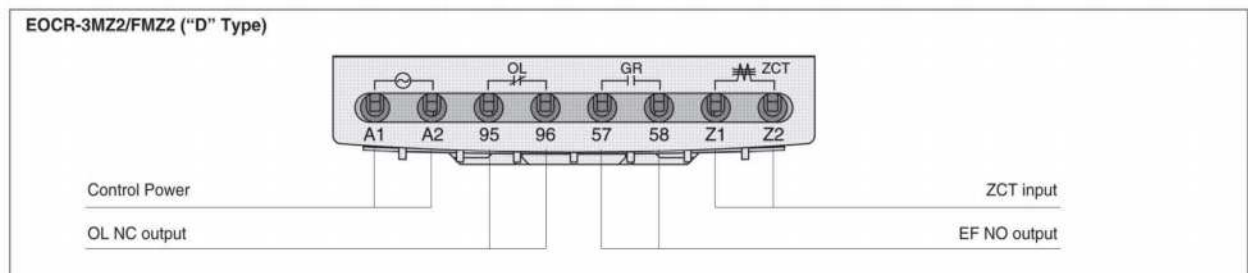
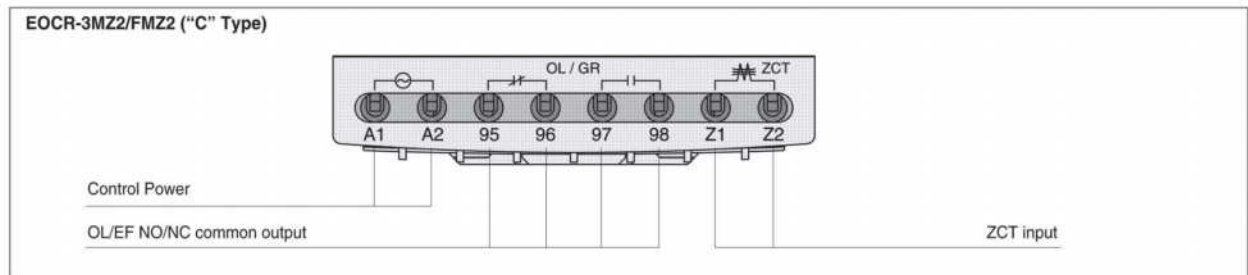
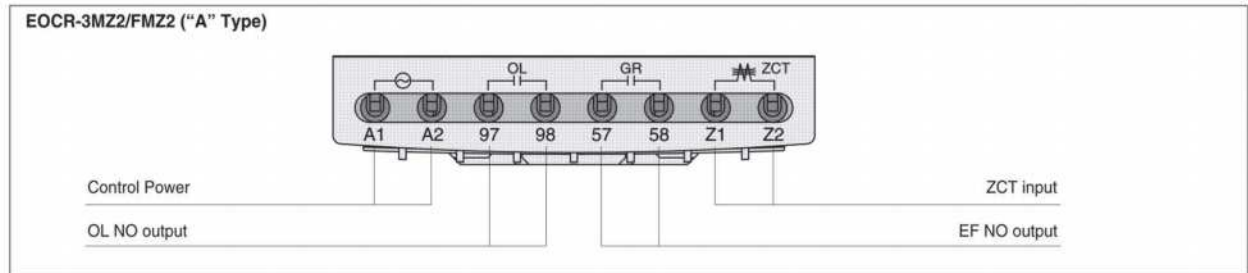
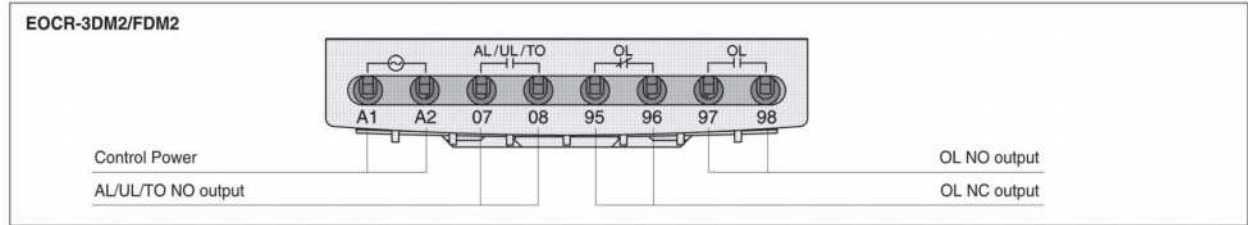

# EOCR-DM2 Series

Basic model : EOCR-3DM2 (Z) / FDM2 (Z)

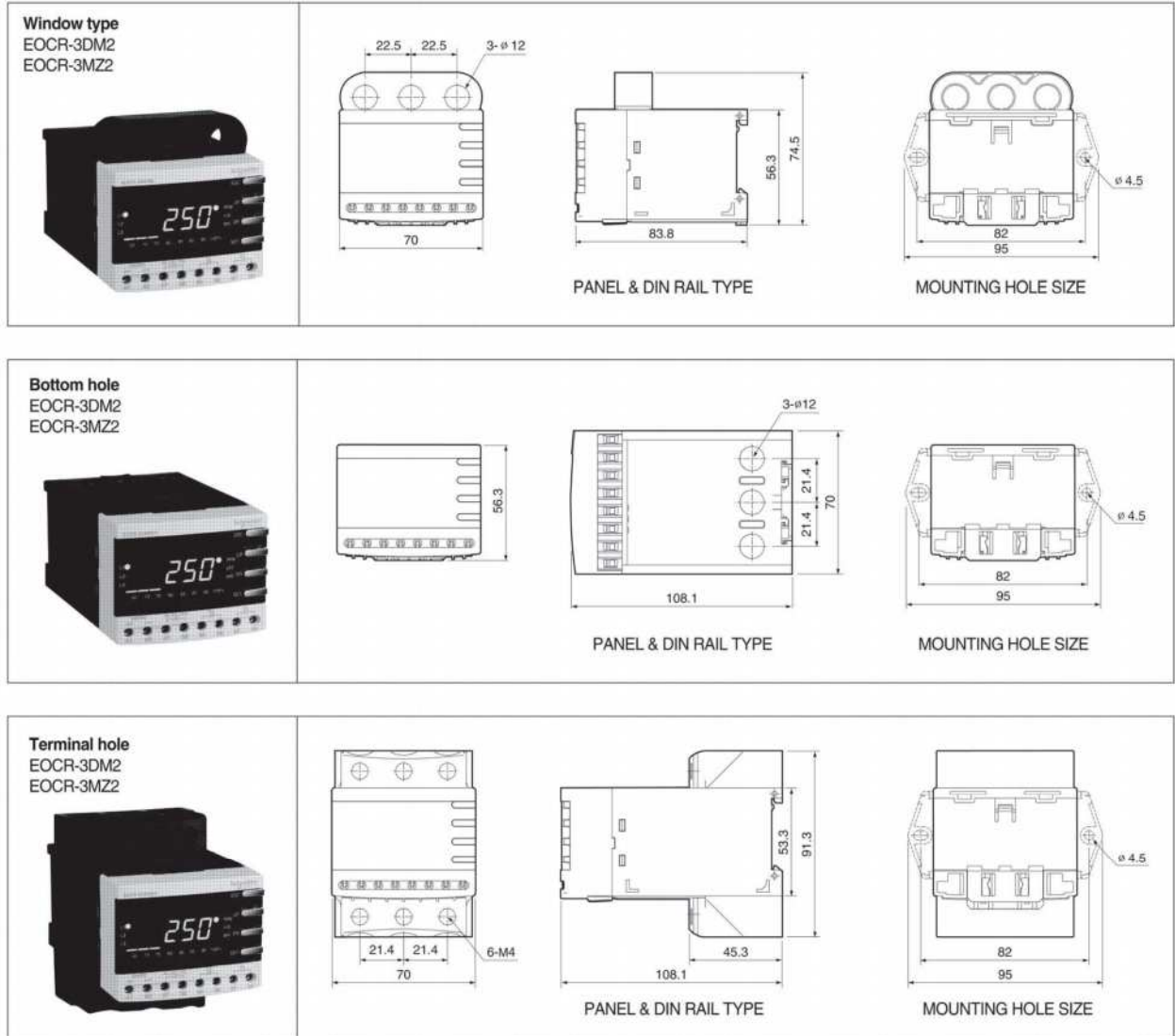

## Dimension of 3XX2



# EOCR-DM2 Series

Basic model : EOCR-i3DM(Z, S, 420) / iFDM (Z, S, 420)

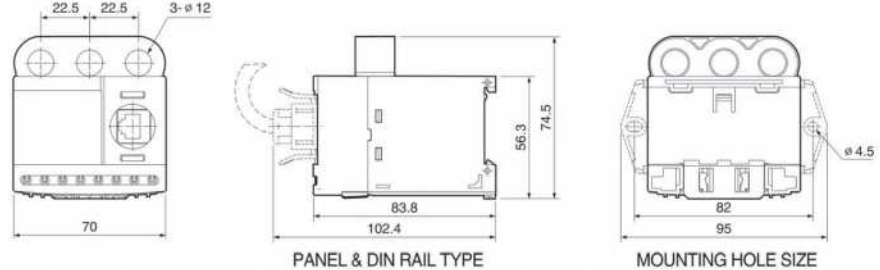
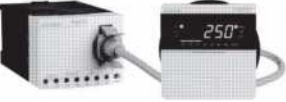
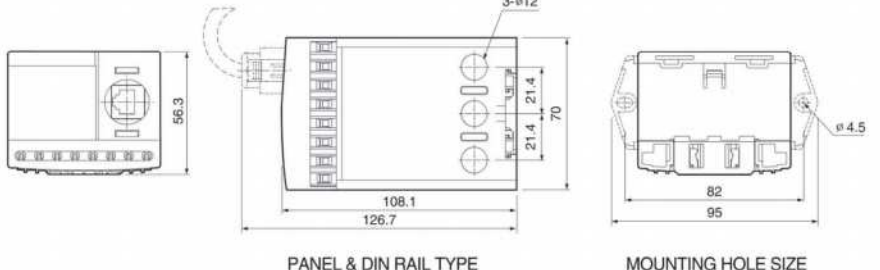
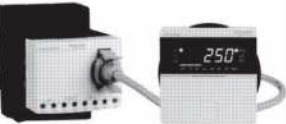
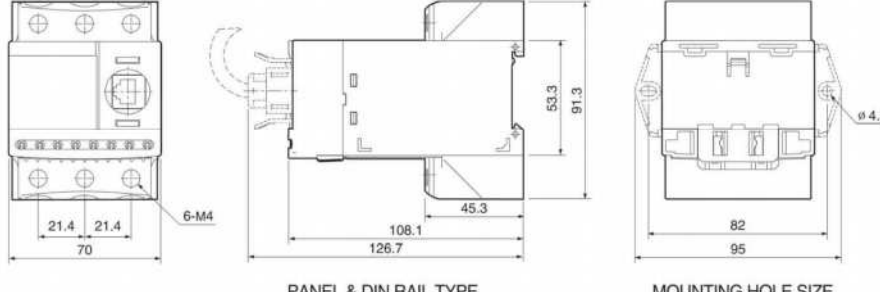
## Dimension of FXX2

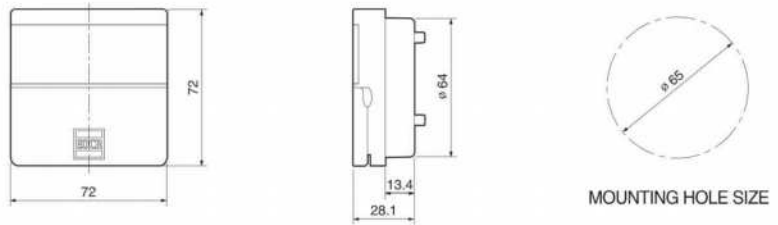
<p><b>Window type</b> EOCR-FDM2 EOCR-FMZ2</p> 	 <p>PANEL &amp; DIN RAIL TYPE</p> <p>MOUNTING HOLE SIZE</p>
<p><b>Bottom hole type</b> EOCR-FDM2 EOCR-FMZ2</p> 	 <p>PANEL &amp; DIN RAIL TYPE</p> <p>MOUNTING HOLE SIZE</p>
<p><b>Terminal type</b> EOCR-FDM2 EOCR-FMZ2</p> 	 <p>PANEL &amp; DIN RAIL TYPE</p> <p>MOUNTING HOLE SIZE</p>
<p><b>Display</b> EOCR-PDM</p> 	 <p>MOUNTING HOLE SIZE</p>

# EOCR-DM2 Series

Basic model : EOCR-i3DM(Z, S, 420) / iFDM (Z, S, 420)

## Ordering

**EOCR-3XX2**



Window CT



Bottom CT



Terminal



External CT combination type

**3DM2 - WR D U W Q**

①	②	③	④	⑤	⑥
①	Model name	3DM2	Basic model		
		3MZ2	GF model		
②	Current range	WR	0.5-60A		
		H1	100:5 3CT combination type		
		HH	150:5 3CT combination type		
		H2	200:5 3CT combination type		
		H3	300:5 3CT combination type		
③	Output contact type	3MZ2	A	a(97-98) : OC, a(57-58) : GR	
			C	b(95-96), a(97-98) : OC.GR common	
		3DM2	D	b(95-96) : OC, a(57-58) : GR	
			D	b(95-96), a(97-98)	
④	Control voltage	B	24VAC/DC		
		U	100-240VAC/DC		
⑤	CT type	W	Window type		
		H	Bottom hole type		
		T	Terminal type		
⑥	Export code	Q			

**EOCR-FXX2**



Window CT



Bottom CT



Terminal



External CT combination type

**FDM2 - WR D U W Q**

①	②	③	④	⑤	⑥
①	Model name	iFDM	Basic model		
		iFMZ	GF model		
②	Current range	WR	0.5-60A		
		H1	100:5 3CT combination type		
		HH	150:5 3CT combination type		
		H2	200:5 3CT combination type		
		H3	300:5 3CT combination type		
③	Output contact type	FMZ2	A	a(97-98) : OC, a(57-58) : GR	
			C	b(95-96), a(97-98) : OC.GR common	
		FDM2	D	b(95-96) : OC, a(57-58) : GR	
			D	b(95-96), a(97-98)	
④	Control voltage	B	24VAC/DC		
		U	100-240VAC/DC		
⑤	CT type	W	Window type		
		H	Bottom Hole type		
		T	Terminal type		
⑥	Export code	Q			

