

# EOCR-3DE/FDE

## Digital Over Current Relay

### EOCR-3DE Built-in Panel



■ Hole Type

### EOCR-FDE Embedded Panel



■ Terminal Type

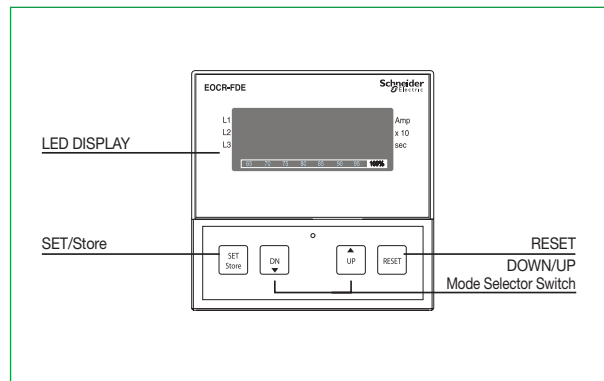
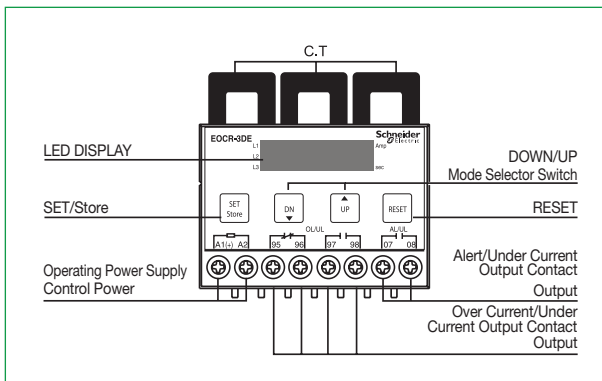

## Main Features

- Built-in MCU (Micro Controller Unit)
- Real Time Processing/Higher Precision
- Over Current Protection Range : 0.5~60A, Wide Range Protection (with an external CT, 1~960A)
- Under Current Protection Range : The set over current or less
- Operation Time Characteristics: Definite - 0.5~60A (external CT combination for 60A or higher), Inverse - 0.5~10A (use an external CT combination for 11A or higher)
- Under Current Trip Output
  - Under Current output is set to be shared with the OC output in the factory default settings. However, if "U" is selected in "ALo" Mode, "AL" Mode automatically switches to OFF(-) and ALoutput (07-| 08) automatically converts to output contact for under current (UC).
- Digital Display
  - 3-phase Current Auto Circulation Display: Digital Ammeter (every 5 sec for each phase) / fixed display on 1 phase by manual circulation
  - Trip Cause Digital Display: Easy Troubleshooting
- Last Trip Cause Check Function: Can check the last 3 trip causes and current at the occurrence of each trip. Available even during the recovery of electricity after a power outage.
- Manual (instant)/electrical (remote) reset
- Fail Safe function (FS:ON)
  - Self-diagnosis function
  - When power is supplied to the relay, the relay is normally energized if it is in a normal condition (selectable in setting)
- Can be applied in various installation environments, with both terminal and hole types available
- Works well with a frequency converting device system such as an inverter: Frequency contingency range of 20~400Hz

## Protection Functions and Characteristics

Protection Function	Operation Time	
<b>Over Current</b>	Operates based on the set ot	
<b>Under Current</b>	Operates based on the set ut	
<b>Phase Loss</b>	Within 3 sec	
<b>Reverse Phase</b>	0.1~0.3 sec	
<b>Unbalance</b>	Within 8 sec	
<b>Locked Rotor</b>	<b>Lock</b>	Operates within 0.5 sec after dt (Definite operation)
	<b>Stall</b>	0.5, 1~10 sec (Definite operation)

# EOCR-3DE/FDE

## Digital Over Current Relay

### Specifications

Functions and Characteristics		Specifications
Current Setting	Over Current	Refer to current setting range table
	Under Current	0.5~59A / oFF (with an external CT : 800A or less)
	Unbalance	5%~50% (Phase current unbalance ratio) / oFF
Time Setting	Start Delay Time (dt)	1~200 sec (Definite), 0~200 sec (Inverse)
	Operation Time (ot)	0.5~30 sec (Definite), 1~30 sec (Inverse)
Reset		Manual (Instant) Reset/Electrical Reset
Operation Time Characteristic	Over Current	Select Definite/Inverse
	Under Current	Refer to the Notes on Current Setting and External CT Combination
Error Tolerance	Current	I < 1A : ±0.05A, I ≥ 1A : ±5%
	Time	t ≤ 3s : ±0.2s, t > 3s : ±5%
Usage Environment	Temperature	Operation -20°C~60°C
		Save -30°C~80°C
	Humidity	30~85% RH (with no dew condensation)
Operating Power Supply	Terminal type	AC220/110V
		- DC/AC85~250V, 50/60Hz
	Hole type	- AC220V : ±15%, 50/60Hz
		- AC110V : ±15%, 50/60Hz
Output Contact	OC/UC 2-SPST	AC250V/3A Resistive Load
	AL/UC 1-SPST	AC250V/3A Resistive Load
Insulation Resistance	Between circuit and case	10MΩ or higher at 500VDC
	Between circuit and case	2.0KV 60Hz for 1 min
Insulation Withstanding Voltage	Between contacts	1.0kV 60Hz for 1 min
	Between circuits	2.0KV 60Hz for 1 min
Installation Method		35mm DIN Rail or Panel

### Over Current Operation Time Characteristic Curve

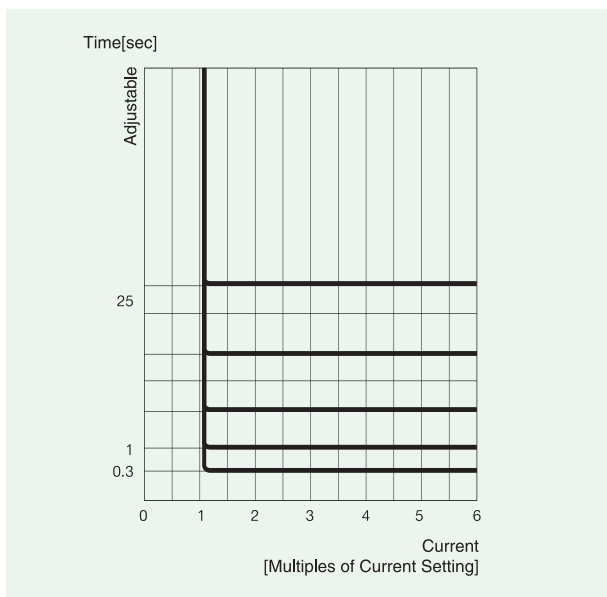

Table 1. Over Current Protection Definite Operation Characteristic Curve

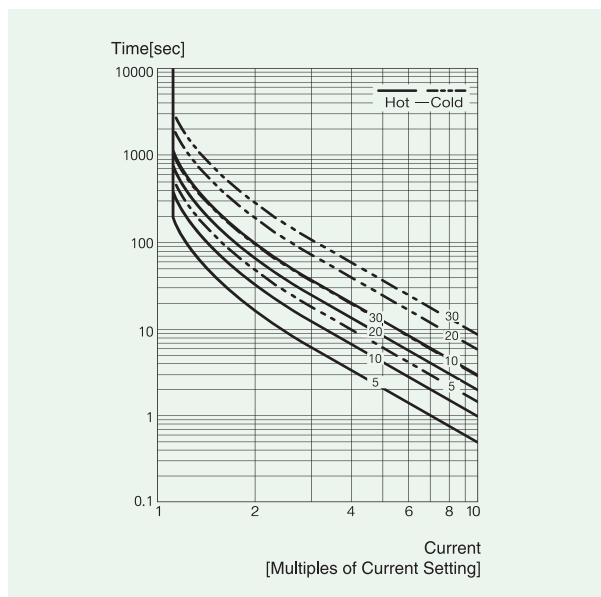

Table 2. Over Current Protection Inverse Operation Characteristic Curve (0.5~10A, external CT combination)

# EOCR-3DE/FDE

## Digital Over Current Relay

### Current Setting Range Table

Setting Range	Number of CT Holes	External CT Current Transformer Ratio	CT Setting	Notes
0.5~60A	1	No CT combination	oFF	Wide Range
0.25~5.0A	2 Holes	No CT combination	2t	
0.1~2.0A	5 Holes	No CT combination	5t	
1~12A	1	10:05	10	
1.5~18A	1	15:05	15	
2.0~24A	1	20:05	20	
2.5~30A	1	25:05:00	25	
3.0~36A	1	30:05:00	30	
4.0~48A	1	40:05:00	40	
5~60A	1	50:05:00	50	
6~72A	1	60:05:00	60	
7.5~90A	1	75:05:00	75	
10~120A	1	100:05:00	100	
12~144A	1	120:05:00	120	
15~180A	1	150:05:00	150	
20~240A	1	200:05:00	200	
25~300A	1	250:05:00	250	
30~360A	1	300:05:00	300	
40~480A	1	400:05:00	400	
50~600A	1	500:05:00	500	
60~720A	1	600:05:00	600	
75~900A	1	750:05:00	750	
80~960A	1	800:05:00	800	

# EOCR-3DE/FDE

## Digital Over Current Relay

### Display Front View

Automatically displays the operating current of 3 phases with the phase display every 5 sec in circulation, without additional button input.

#### • LED Display

EOCR-3DE Type

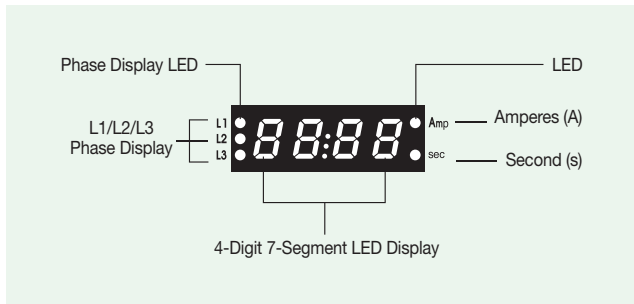

EOCR-FDE Type

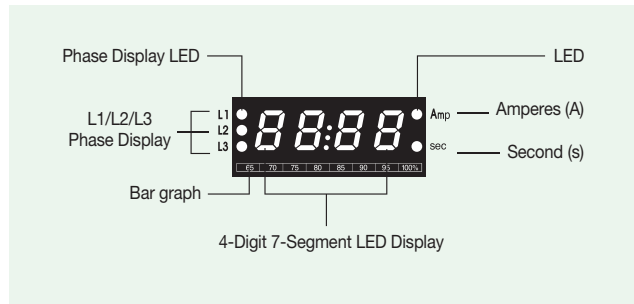

#### 7-segment LED

A large font and a comfortable background color are used to prevent visual interference caused by reflections from the control panel in any direction.

#### Bar graph (for FDE only)

- Allows you to see the load status of the motor by showing the ratio of the present operating current to the set OC (Over Current).
- If you set the OC set value to the rated current of the motor, the percentage (%) shown on the bar graph will indicate the load factor of the motor.

### 3-phase Digital Current System Function

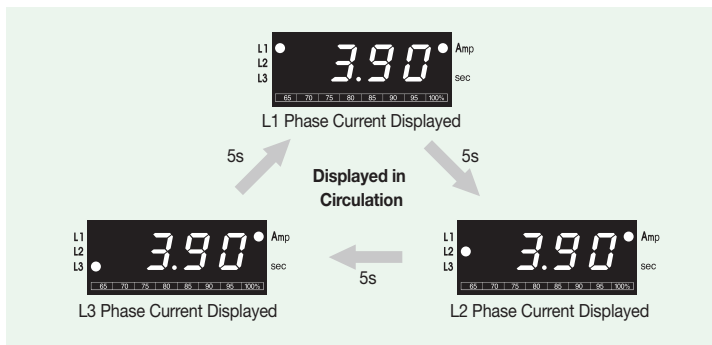







- ※ Press the SET (Store) button once during operation to view the manual circulation display instead of auto circulation display. Every time you press the SET (Store) button while in manual circulation mode, the display changes in the order specified above, allowing you to lock on the current of a certain phase for focused management.
- ※ Press the Reset button once to switch back to the auto circulation display.

# EOCR-3DE/FDE

## Digital Over Current Relay

### Button Switch Functions and Setting Sequence

<b>Mode</b>	 	Press the Up/Down buttons to find the function to set.
<b>Set</b>		This mode indicates the start of the setting. When this button is pressed once, the corresponding value or characters flicker 5 times, during which you should continue the setting process. If there is no input for 30 seconds, it will be reset and you will have to press this button again to adjust the settings.
<b>Adjust</b>	 	Press the Up/Down buttons to select the necessary value or characters.
<b>Store</b>		When the SET (store) button is pressed once, the selected value or characters are stored and the flickering stops at the same time.
<b>Reset</b>		Reset button is used to return to the initial state. Once the setting is done, press the Reset button or leave it for 30 seconds to complete the setting.

※ Manual Circulation Display

- If you press the Set (Store) button during operation, the display of 3-phase current is switched from auto circulation display to manual circulation display.
- Once the original L1 phase is displayed, every time you press it, the phase display will change in the order of L2→L3→L1 phase. Press Reset to return to the auto circulation display state.

※ Trip Cause Check

- After pressing the Up/Down buttons to enter "Trip" Mode, press the Set/Store button once to display the last trip cause. Every time the Up button is pressed, the current at each phase (L1, L2, L3) at the time of the trip will be displayed. Press it once more to check the second-last trip cause. The method for checking subsequent fault causes and current during operation is the same as the one used for checking the last trip cause.

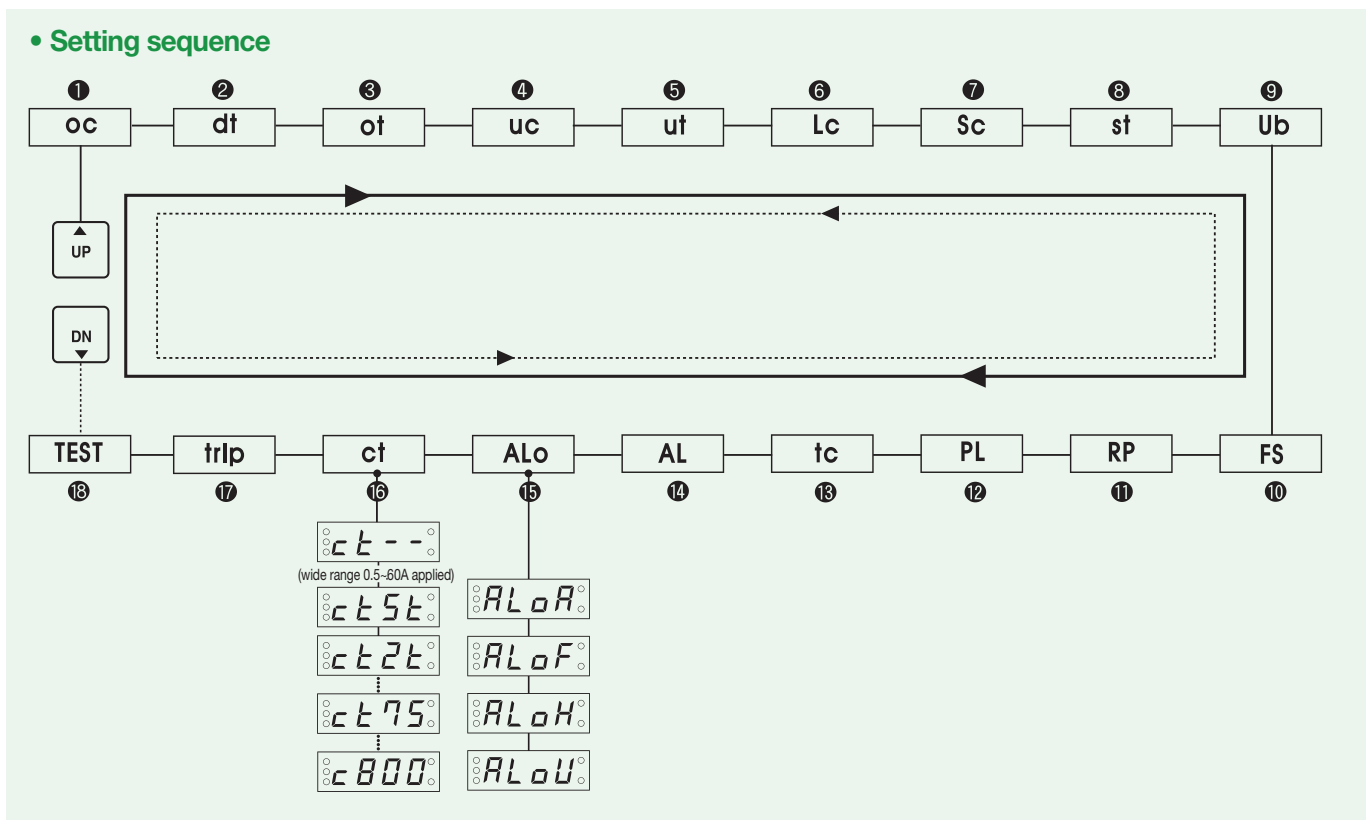

- Press the UP/Down buttons to find the Mode to set.
- To find ot in this figure, press the UP SW button 3 times if you are rotating the sequence of modes in a clockwise direction, then ot will appear in the display window.

# EOCR-3DE/FDE

## Digital Over Current Relay

### Function Setting Sequence and Setting Menu

Sequence	Settings	Display	Description	Setting Range	Default
1	Over Current Setting	oc 0.5°	<ul style="list-style-type: none"> <li>Set your desired over current value.</li> <li>Set it higher (100%~125%) than the active load current (operating current).</li> <li>Current of 0.4A or higher can be displayed, but setting and operation are only available at the current of 0.5A or higher.</li> <li>0.5~10A: Changes in increments of 0.1A, 10~60A: Changes in increments of 1A</li> <li>Cannot set to the UC set value or less.</li> <li>For Inverse, the setting cannot exceed 10A.</li> <li>When setting the CT Ratio, the protection set value converted based on the secondary CT (=primary active current/CT Ratio) must be set in "OC" Mode before setting the Ratio in "CT" Mode.</li> <li>Check the current value in "OC" Mode after setting the CT Ratio, and you will recognize that it is automatically converted to the active current value based on the primary CT.</li> <li>Afterwards, the active current value can be changed to any value in the "OC" Mode for the identical CT ratio.</li> </ul>	Current Setting Range Table	10
2	Start Delay Time Setting	dt 1.0.	<ul style="list-style-type: none"> <li>This function stops the operation of start-up over current, under current, and lock functions. Must be set accurately.</li> <li>Phase loss and reverse phase still work normally during the set time period.</li> <li>1~100 sec: Changes in increments of 1 sec.</li> <li>100~200 sec: Changes in increments of 10 sec.</li> </ul>	<ul style="list-style-type: none"> <li>Can be set from 1~200 sec oFF (Mode display: - -)</li> </ul>	10
3	Over Current Operation Time Setting	ot 1.0.	<ul style="list-style-type: none"> <li>Definite/Inverse can be selected and set in the tc mode.</li> <li>0.2~1 sec: Changes in increments of 0.1 sec.</li> <li>1~30 sec: Changes in increments of 1 sec.</li> </ul>	<ul style="list-style-type: none"> <li>Can be set from 0.5~0.9-1...sec (definite time)</li> <li>Can be set from 1~30 sec (inverse time)</li> </ul>	5
4	Under Current Setting	uc 0.5°	<ul style="list-style-type: none"> <li>Sets the preferred under current (light load current) value.</li> <li>Cannot be the same as OC set value or higher.</li> <li>0.5~10A: Changes in increments of 0.1A.</li> <li>10~59A: Changes in increments of 1A.</li> </ul>	<ul style="list-style-type: none"> <li>Can be set from 0.5~59A oFF (Mode display: - -)</li> </ul>	--
5	Under Current Operation Time Setting	ut 1.0.	<ul style="list-style-type: none"> <li>Sets the operation time of the relay for the set under current (light load).</li> <li>Definite Operation</li> <li>0.5~1 sec: Changes in increments of 0.1 sec.</li> <li>1~30 sec: Changes in increments of 1 sec.</li> </ul>	Can be set from 0.5~30 sec	--
6	Lock (Stall) Current Setting: A multiple of OC set value.	Lc 7	<ul style="list-style-type: none"> <li>Set as a multiple of over current set value.</li> <li>Definite Operation</li> <li>Operates within 0.5 sec if the current exceeds the set multiple value after dt.</li> <li>Does not operate during operation.</li> </ul>	<ul style="list-style-type: none"> <li>0.5~10A: 2~10 times the over current setting</li> <li>11A or higher: Automatically reduced to an appropriate multiple value. The upper value set for "Lc" is "[ Lc" upper value=100/OC set value], during which "Lc" can be changed to the range of upper value or below.</li> <li>oFF (Mode display: - -)</li> </ul>	10
7	Stall (heavy load during operation) or Shock (mechanical shock) Current Setting: A multiple of OC Set Value	Sc 2.0	<ul style="list-style-type: none"> <li>Set to 1.5 times the over current set value.</li> <li>Definite Operation</li> <li>If the current flow exceeds the multiple of the SC set value due to heavy load during normal operation after startup, it will be tripped after the time set for St elapses.</li> </ul>	<ul style="list-style-type: none"> <li>0.5~10A : 1.5~5 times more</li> <li>11A or higher: Automatically reduced to an appropriate multiple value. The upper value set for "Sc" is "[ Sc" upper value=100/ OC" set value], during which "Sc" can be changed to the range of upper value or below.</li> <li>oFF (Mode display: --)</li> </ul>	5
8	Stall Operation Time Setting	St 5.0.	<ul style="list-style-type: none"> <li>When Sc is set to oFF(--), St is also automatically displayed as oFF(--).</li> <li>Operates with the setting of 0.5 sec for shock protection</li> </ul>	<ul style="list-style-type: none"> <li>0.5, 1~10 sec oFF (Mode display: - -)</li> </ul>	5
9	Current Unbalance Setting	Ub 10	<ul style="list-style-type: none"> <li>Sets the unbalance ratio of the phase current by the equation of [(Max. phase current - min. phase current)/ max. phase current] × 100) set %</li> </ul>	<ul style="list-style-type: none"> <li>5~50% oFF (Mode display: - -)</li> </ul>	50
10	Fail Safe (NVR) Function	F5 on	<ul style="list-style-type: none"> <li>Cannot be set while operating.</li> </ul>	ON, OFF (Mode display: - -)	OFF

# EOCR-3DE/FDE

## Digital Over Current Relay

Sequence	Settings	Display	Description	Setting Range	Default
11	RPR (Reverse Phase Relay) Function		• Reverse phase function is disabled when set to oFF(-).	ON, oFF (Mode display: - -)	ON
12	Phase Loss Function Select		• Can be set to oFF(-). (Set to off for single-phase)	ON, oFF (Mode display: - -)	ON
13	Over Current Protection Operation Time Characteristics (select Definite/Inverse)		<ul style="list-style-type: none"> <li>• tc (Time-Current Characteristic) : dE, In</li> <li>- Definite (dE): Operates based on operation characteristics on Table 1.</li> <li>- Inverse (In): Operates based on characteristics curve in Table 2.</li> <li>- When set to 11A or higher, dE is automatically applied.</li> <li>※ Once Inverse (tdIn) is selected and operation delay time (dt) is set, hot curve will be applied after dt. When using inverse time for a longer startup time, it is possible to set faster operation time on overload during operation.</li> </ul>	<ul style="list-style-type: none"> <li>• dE(definite), In(Inverse)</li> <li>• 0.5~10A: Can select dE/In</li> <li>• 11A or higher: dE is used (not when using external CT)</li> </ul>	dE
14	Alert Rate Setting		<ul style="list-style-type: none"> <li>• Setting within the 90% range of OC set value is recommended.</li> <li>• When selecting "U" from "ALO", "AL" is displayed as oFF(-).</li> </ul>	50%~100% of OC set value/oFF	100
15	Alert Output Format		<ul style="list-style-type: none"> <li>• Output Format</li> <li>"A" (Ampere relay function): Energized upon current detection.</li> <li>"F" (Flicker): Flickers.</li> <li>"H" (Holding) : ON-oFF output format</li> <li>"U" (Under current Mode) : AL output is converted to under current output.</li> <li>• Cannot be set while operating.</li> </ul>	Output Format of 07-08 contact when the current exceeds the alert set value	A--
16	CT Current Transformer Ratio Setting		<ul style="list-style-type: none"> <li>• Automatically sets to the wide range (0.5~60A) mode if set to oFF(-).</li> <li>• Cannot set the CT scale while operating.</li> <li>• 5t: Protectable at 0.12A or higher</li> <li>• 2t: Protectable at 0.3A or higher</li> <li>• To set the CT Ratio, the target active current value for protection should be converted to the secondary value (=active current value/CT ratio), and the resulting value must first be set in "OC" Mode. (see the "OC" Mode setting guide for details)</li> </ul>	OFF-5t, 2t, 10-15-25-30-40-50-60-75-100-120-150-200-250-300-400-500-600-750-800	--
17	Trip Cause Check		• Displayed in the order of the Last-2nd Last-3rd Last trip. Trip causes and the current for each phase can be checked.	Can check from the 1st to the 3rd	
18	TEST Function			Does not convert to Test while operating. (to prevent tripping during operation)	

Inspection after installing EOCR should be performed as follows:

- Confirm that the wiring has been performed properly.
- Press the Down button once before starting the motor to show the Test display. 3 seconds after it is displayed, a countdown of the set ot value will start. If End is displayed after the countdown, it is normal.
- EOCR is designed to block the test function during operation to prevent unnecessary trip accidents.
- The Test function checks to ensure the health status of EOCR itself and the operational circuit after installing EOCR is normal.

# EOCR-3DE/FDE

## Digital Over Current Relay

### How to Set Current/Time

Protects the motor by setting the current and time appropriately, as follows:

#### • Notes on Current Setting

1. Wide Range: If CT is set to --(OFF), it switches to the wide range. The range of working current can go up to 0.5A~60A for Definite (set to todE), and up to 0.5A~10A for Inverse (set to toIn).  
*※ You can select either Definite or Inverse if the OC set value is 10A or lower. However, if the OC set value is 10A or higher, the Inverse setting is not allowed. Similarly, OC set value cannot be 10A or higher when it is set to Inverse (toIn).*

#### 2. External CT Combination

- CT ratio cannot be adjusted if OC (Over Current) set value is 6A or higher.
- CT setting sets the primary current value of an external CT. Once set, it is displayed as CT75 if the CT primary current is 75:5 or lower during the setting, and displayed as c100 if it is 100:5 or higher.
- The current range available when using an external CT is calculated as follows: CT ratio (i.e.,  $100:5=100/5=20$ ) $\times$ 0.5-6A=10-120A  
*※ • Once the current transformer ratio of CT is set, OC setting will not display the letter "c" in "OC"; instead, it will be displayed as o10.8 without the "c".*
  - Similarly, the under current setting will not display "c" of "UC" and will be displayed as u9.80, for example.
- Over Current Setting Sequence
  - Set the OC (Over Current) value to 6A or lower.
  - Set the CT ratio. The OC (Over Current) that is already set will be automatically converted to the value multiplied by the current transformer ratio of the CT (20 times if 100:5). For example, if OC is set at 4A and CT at 200, the over current setting is automatically set to  $4\times 20=80$ A and saved.
  - Simply check the over current setting and set it appropriately for the load.

#### 3. Operation Time

- Definite: Set the time it takes for the current exceeding the set point to start to flow and trip the relay to ot.
- Inverse: Decide when the relay will be tripped in terms of after how much time has elapsed and after what multiple value of the set current flows with reference to the current-time characteristic curve, and complete the setting. Consider the figure below as an example. If ot is set to 5 and the current flow is 5 times the regular current, the relay will be tripped at 2 sec; if ot is set to 10, at 4 sec.

#### • Under Current Protection

1. It is more convenient to set to UC--(OFF) to prevent malfunction during startup for a test operation. Even during the test operation, it operates with no-load because the current flow is only one-third the rated current during no-load.
2. During normal operation, check the current in no-load state, and set the current to be slightly higher than the current in no-load state (to prevent no-load operation).
3. If under current function is unnecessary, the function is removed if set to UC--(OFF), and the over current operation time ut is removed as well.

# EOCR-3DE/FDE

## Digital Over Current Relay

### Alert Operation Characteristics Table

"ALo Setting"	Load Status	Load Interruption	In Operation	Normal Operation	Operates at the Alert Set Value or a higher value	Trip
Aux "A"						
Flicker "F"					1 sec	
Hold "H"					1 sec	

- ALo "A": Ampere Relay function (energized and closed when current flows)
- ALo "F": Flickering function (closes when current flows and repeats closing and opening for the current equal to the AL set value or higher)
- ALo "H": ON-OFF Output Format function (closes at the AL set value or higher)
- ALo "U": AL output converts to "UC" (under current) output contact

- Output format and terminal configuration if ALo "A", ALo "F", or "ALo "H" is selected

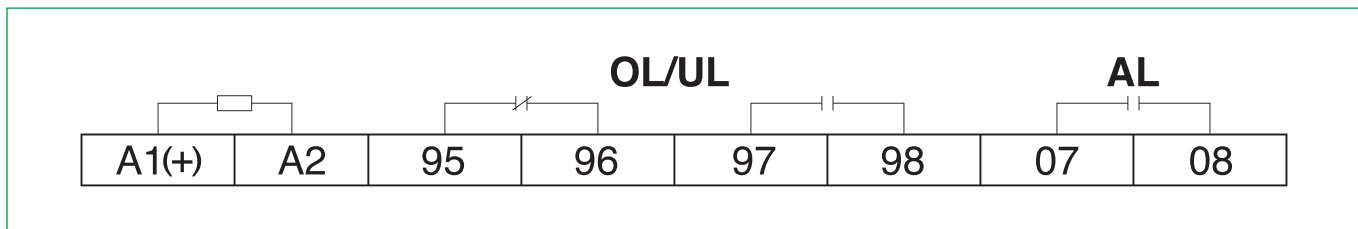

- Output terminal configuration if ALo "U" is selected: ALo function is not available, and is converted to the output for under current

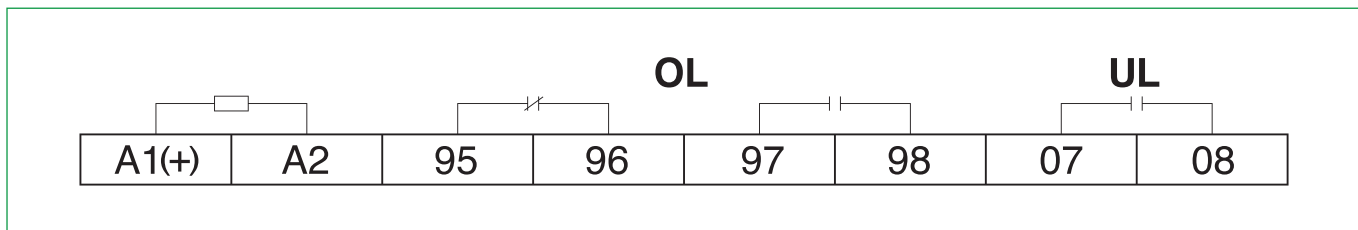

### Trip Cause Display and Check Method

Displays all kinds of trip causes and fault current values on the digital display window, enabling easier maintenance and faster responses to accidents.

Trip Cause	Display	Description	Notes
Over Current		Detects over current at L1 (R) phase during operation and indicates operation.	<p>Capable of checking the current for each phase by pressing the switch after trip</p>
Under Current		Detects under current at L2 (S) phase during operation and indicates operation.	
Phase Loss		Indicates operation due to a phase loss at L2 (S) phase.	
Reverse Phase		Displays reverse phase trip.	
Unbalance		Indicates that it operates due to a phase unbalance calculated by $[(\text{max. phase current} - \text{min. phase current}) / \text{max. phase current}] \times 100 > \text{set \%}$ , and that min. current at the time is at L1 (R) phase.	
Locked Rotor		Detects stall and indicates operation.	
Jam Trip During Operation		Displays trip due to stall or mechanical shock caused by heavy load at L3 (T) phase during operation.	

# EOCR-3DE/FDE

## Digital Over Current Relay

### Example Wiring Diagram

EOCR installation must be wired as shown below.

-Installation on either the frontal or rear part of the MC is allowed.

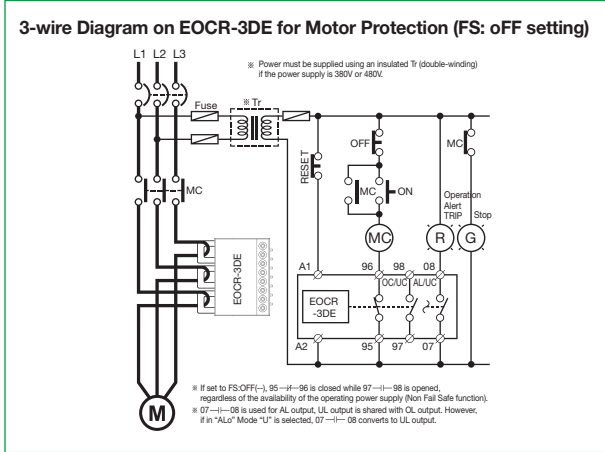

※ OL output 95-|-96 is opened and 97-|-98 is closed when FS is set to ON and operating power is supplied to A1 and A2

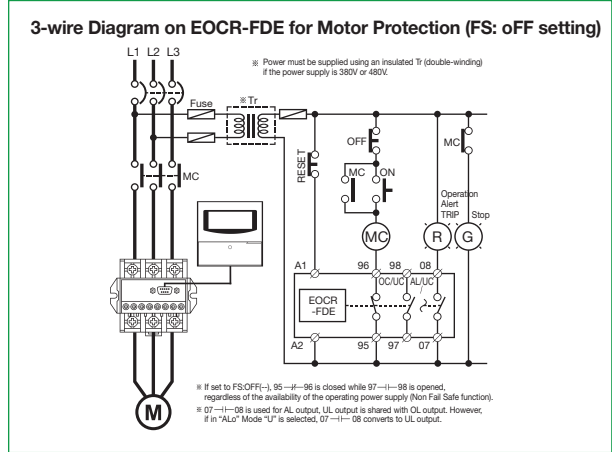

※ OL output 95-|-96 is opened and 97-|-98 is closed when FS is set to ON and operating power is supplied to A1 and A2.

### I/O Terminal Configuration

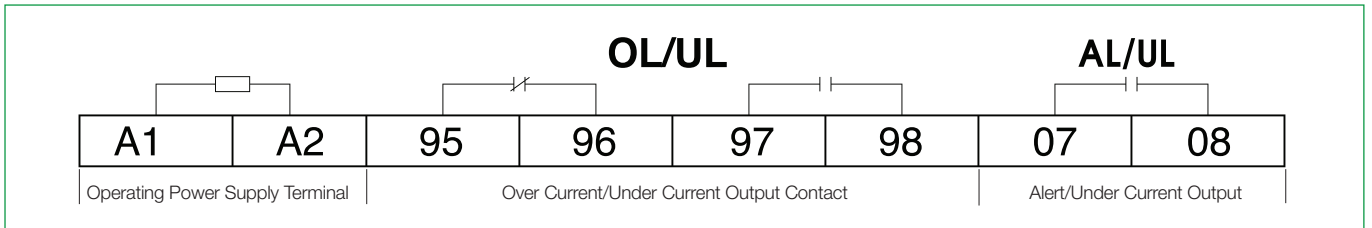





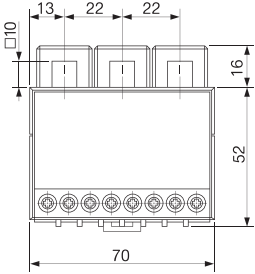
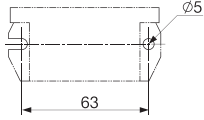

※ The operating power supply must be connected to operating power supply terminals (A1, A2) and the specified operating voltage should be applied.

# EOCR-3DE/FDE

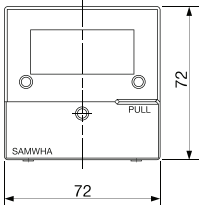
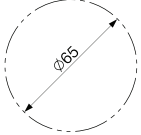
## Digital Over Current Relay

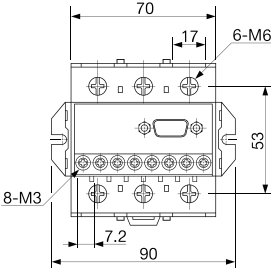
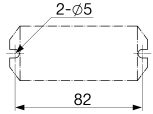
### Dimensions Diagram

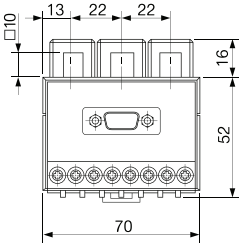
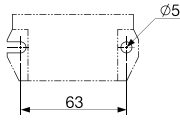
 <p>EOCR-3DE</p>		 <p>BRACKET HOLE SIZE</p>
 <p>EOCR-FDE</p>		 <p>MOUNTING HOLE SIZE</p>
 <p>EOCR-FDE (Terminal Type)</p>		 <p>MOUNTING HOLE SIZE</p>
 <p>EOCR-FDE (Hole Type)</p>		 <p>BRACKET HOLE SIZE</p>