

# Samwha Motor Protection Relays

## Quick Selection Chart

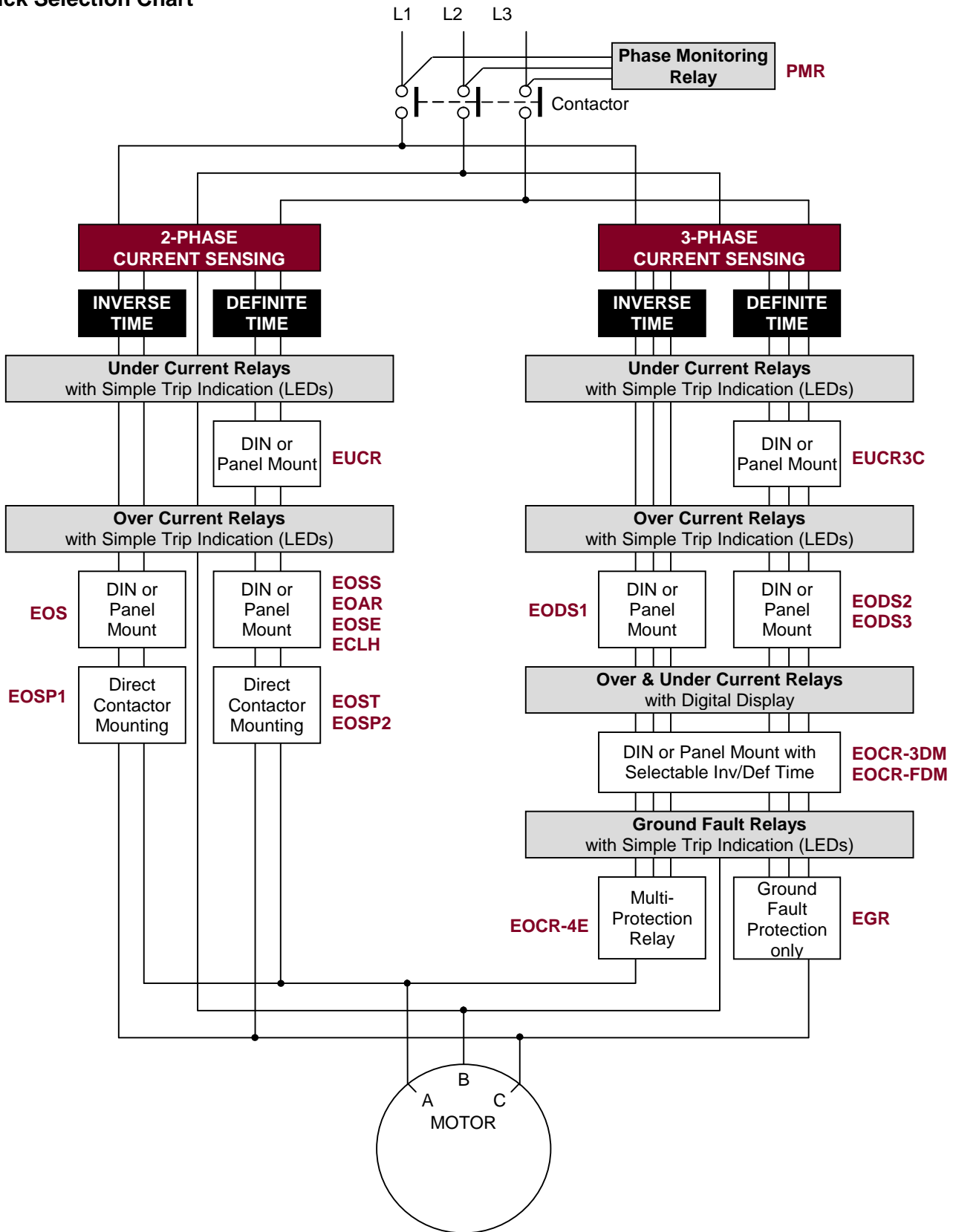

**QUESTION:** How much money should I spend on an overload relay?

**ANSWER:** How much will it cost to replace the motor should it burn out, in both money and down time?

**THE RIGHT SELECTION WILL SAVE MONEY EVERY TIME**

**Model PMR – Phase Monitoring Relay**

PART NUMBER		APPLICATION VOLTAGE												
PMR-440		340 ~ 480Vac												
<p><b>Applications</b> Ideal for use on submersible pumps, refrigeration compressors, supplies for portable generating plants, etc. Designed to detect 3-phase line inputs for monitoring phase conditions.</p> <p><b>Features</b></p> <ul style="list-style-type: none"> <li>Phase reversal, phase loss and adjustable voltage unbalance protection</li> <li>Fail-safe operation (no voltage release)</li> <li>Panel and DIN rail mounting</li> <li>Dimensions: 107H x 50W x 79D mm</li> </ul> <p><b>Technical Specifications</b> Application Voltage .....3-Phase 340~480V 50/60Hz Output Contact .....SPDT 3A / 250Vac resistive Reset Method ..... - Auto-Reset 5 sec - Manual or remote electrical</p> <table border="1"> <thead> <tr> <th>PROTECTION</th> <th>TRIP TIME</th> <th>DESCRIPTION</th> </tr> </thead> <tbody> <tr> <td>Phase Reversal</td> <td>Within 0.1 sec</td> <td>When abnormal phase sequence power is applied</td> </tr> <tr> <td>Phase Loss</td> <td>Within 1 sec</td> <td>When phase failure occurs</td> </tr> <tr> <td>Voltage Unbalance</td> <td>5 sec</td> <td>OFF or 2 ~ 15% (adjustable) <math>\% = \frac{\text{max deviation from AVERAGE}}{\text{AVERAGE}} \times 100</math></td> </tr> </tbody> </table>			PROTECTION	TRIP TIME	DESCRIPTION	Phase Reversal	Within 0.1 sec	When abnormal phase sequence power is applied	Phase Loss	Within 1 sec	When phase failure occurs	Voltage Unbalance	5 sec	OFF or 2 ~ 15% (adjustable) $\% = \frac{\text{max deviation from AVERAGE}}{\text{AVERAGE}} \times 100$
PROTECTION	TRIP TIME	DESCRIPTION												
Phase Reversal	Within 0.1 sec	When abnormal phase sequence power is applied												
Phase Loss	Within 1 sec	When phase failure occurs												
Voltage Unbalance	5 sec	OFF or 2 ~ 15% (adjustable) $\% = \frac{\text{max deviation from AVERAGE}}{\text{AVERAGE}} \times 100$												

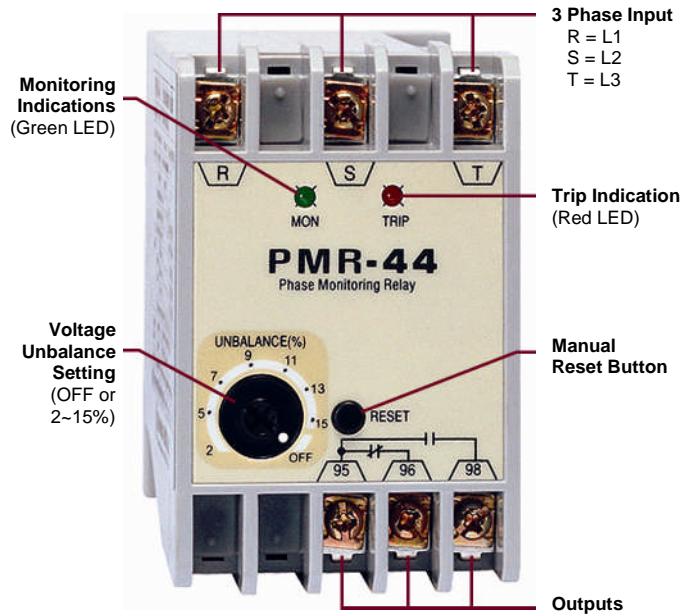

**Models EUCR – Undercurrent Relays**

PART NUMBER		CURRENT RANGE
<b>2 Phase Sensing Model</b>		
EUCR 052		0.5 ~ 5A
EUCR 302		3 ~ 30A
EUCR 602 ①		5 ~ 60A
<b>3 Phase Sensing Model</b>		
EUCR3C 052		0.5 ~ 5A
EUCR3C 302		3 ~ 30A
EUCR3C 602 ①		5 ~ 60A
<p><b>Applications</b> Suitable for protecting pumps from dry running. ➤ <b>EUCR model</b> – Ideal for delta connected and single phase heater elements. ➤ <b>EUCR3C model</b> – Ideal for star connected heater elements.</p> <p><b>Features</b></p> <ul style="list-style-type: none"> <li>DIN rail or panel mounting</li> <li>Dimensions: - EUCR: 65H x 54W x 60D mm - EUCR3C: 71H x 70W x 66D mm</li> </ul> <p><b>Technical Specifications</b> Control Supply .....220 ~ 240Vac Output Contact .....3A / 250Vac resistive - EUCR: SPDT - EUCR3C: DPDT (fail-safe) Reset Method ..... - Manual or remote electrical</p>		

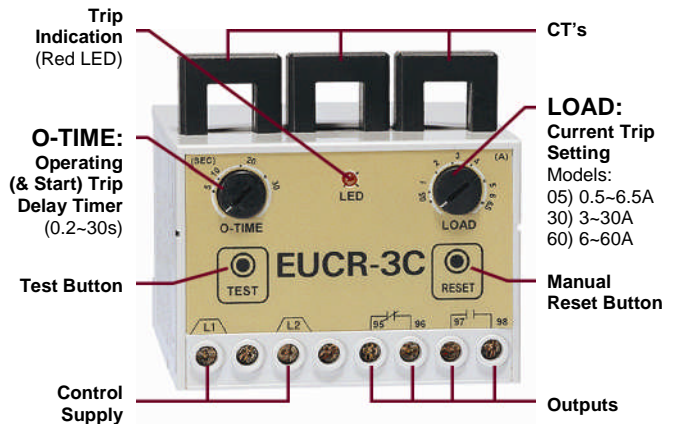

Notes: ① Cable size maybe a limiting factor for 60A models.  
- For ranges over 60A, use EUCR(3C) 052 with external CT's.

## 2-Phase Sensing Overcurrent Relays Summary Table

MODEL		EOSS	EOAR	EOS	ECLH	EOSE	EOST	EOSP1	EOSP2
Time Characteristics	Definite Time	●	●		●	●	●		●
	Inverse Time			●				●	
Protection Functions	Over-Current	●	●	●	●	●	●	●	●
	Phase Loss	□	□		□	□	□	●	●
	Locked Rotor	□	□		□	□	□	□	●
	Short Circuit			●					
Other Features	Auto Reset Timer		●						
	Separate Start Timer	●						▲	▲
	Shear-Pin Function	●			●				
	Fine Load				●				
Wiring & Mounting	Pass-Thru CT	●	●	●	●	●			
	Contact Mount						●	●	●
	DIN/Panel Mount	●	●	●	●	●			
Technical Specifications	Processor	Solid State Circuitry						Microprocessor Based	
	Control Voltage	90 ~ 260V AC		200 ~ 240V AC		180 ~ 250V AC			
	Rated Voltage	Max 600V AC							
	Output Contacts Mode & Rating	SPDT						2x SPST 1NO/1NC	
	Fail Safe Operation	Above models have "No Volt Release" Protection as standard							
	Trip Indication	LEDs							
	Reset Method	Manual Reset Button or Electrical (remote) Reset by interrupting power supply (EOAR also has auto-reset facility)							

Notes: □ Protected by Over-Current Protection Function.  
▲ EOSP models have independent starting and operating trip delay times, but only EOSP2 has an adjustable starting delay timer.

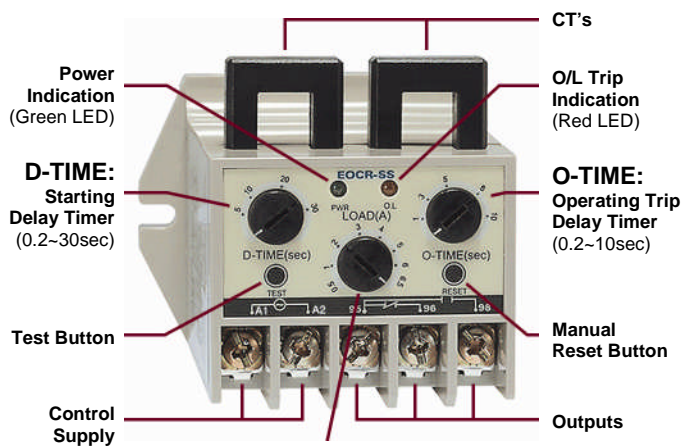

**LOAD: Current Setting**  
Models: 05) 0.5-6.5A  
30) 3-30A  
60) 6-60A



**EOSS 100**  
(EOSS 052 with external CT's)

### Model EOSS – Definite Time, Shear-Pin

PART NUMBER	CURRENT RANGE
<b>EOSS 0524</b> ①	0.5 ~ 6.5A
<b>EOSS 052</b>	0.5 ~ 6.5A
<b>EOSS 302</b>	3 ~ 30A
<b>EOSS 602</b> ②	6 ~ 60A
<b>EOSS 100</b> ③	20 ~ 100A
<b>EOSS 200</b> ③	40 ~ 200A

#### Applications

Ideal for situations where motor loads can be stalled or jammed (eg. Conveyors).

#### Features

- Electronic shear-pin function
- Separate adjustable starting and operating trip delay timers
- DIN rail and stand alone mounting
- Dimensions: 66H x 72W x 60D mm

Notes: ① EOSS 0524 has 24Vac/dc supply voltage. All other models are 90-260Vac. Other supply voltages available on request.  
② Cable size maybe a limiting factor for 60A models.  
③ Supplied with a 2CT module (see EOSS 100 image).  
- For ranges over 60A, use EOSS 052 with external CT's.

**Model EOAR – Definite Time, Auto-Reset**

PART NUMBER	CURRENT RANGE
EOAR 052	0.5 ~ 6A
EOAR 302	3 ~ 30A
EOAR 602 ❶	6 ~ 60A

**Applications**

Ideal for controlling conveyors feeding crushers or similar applications.

**Features**

- Adjustable auto reset time 0.2 ~ 120 seconds
- Single timer for starting and operating trip delay
- DIN rail and stand alone mounting
- Dimensions: 66H x 72W x 60D mm

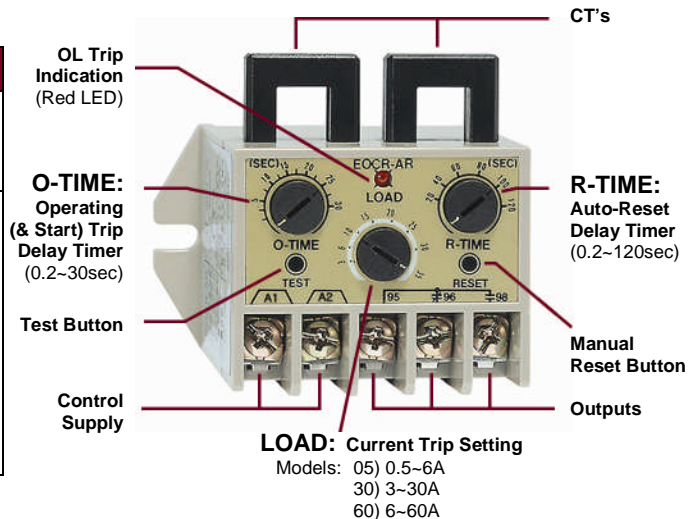

**Model EOS – Inverse Time, Short Circuit**

PART NUMBER	CURRENT RANGE	
	Main	Instantaneous
EOS 052	0.5 ~ 6.5A	20 ~ 80A
EOS 102	2 ~ 14A	40 ~ 100A

**Applications**

Ideal for large and high voltage motors.

**Features**

- Adjustable instantaneous overcurrent protection
- Adjustable trip curve (1-5 sec) @ 600% of load
- Single timer for starting and operating trip delay
- DIN rail and stand alone mounting
- Dimensions: 66H x 72W x 60D mm

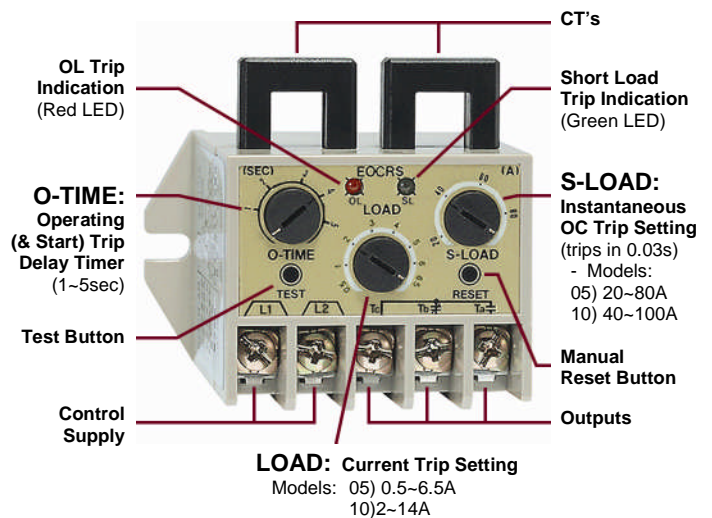

**Model ECLH – Definite Time, Fine Loads**

PART NUMBER	CURRENT RANGE	
	Main	Instantaneous
ECLH 052	0.5 ~ 6.5A	0.2 ~ 0.5A
ECLH 302	3 ~ 30A	0.2 ~ 0.5A
ECLH 602 ❶	5 ~ 60A	0.2 ~ 1.0A

**Applications**

For hoists, lifts, elevators and applications where fine overload settings are required.

**Features**

- Two separate load current adjustments:
  - Main Load Knob and Fine Load Knob
- Electronic shear-pin function
- Manual or electric reset, with options:
  - Type SH: Instant electrical reset
  - Type RD: Delayed reset (set by O-TIME)
- Single timer for starting and operating trip delay
- DIN rail and stand alone mounting
- Dimensions: 66H x 72W x 60D mm

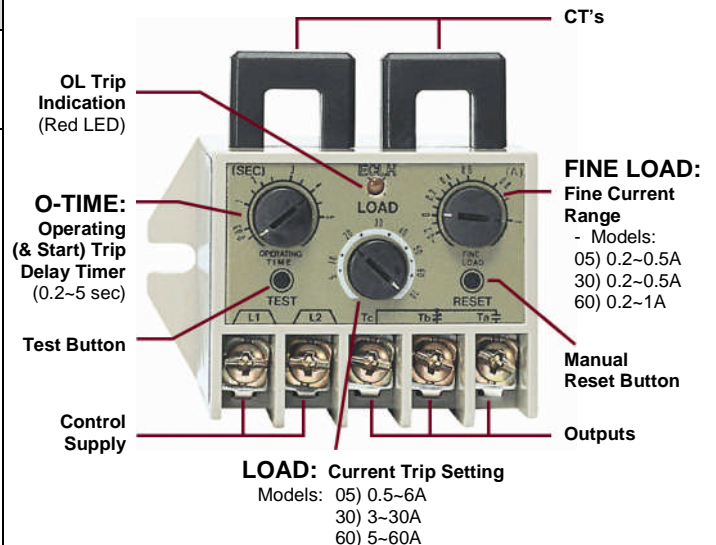

Notes: ❶ Cable size maybe a limiting factor for 60A models.  
 - For ranges over 60A, use EOAR/EOS/ECLH 052 with external CT's.

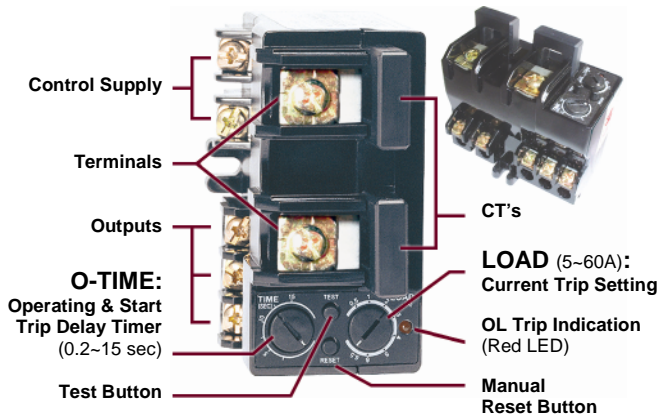

**Model EOSE – Definite Time, w/Terminals**

PART NUMBER	CURRENT RANGE
EOSE 604 ①	5 ~ 60A

**Features**

- Built-in terminals for ease of connection
- Single timer for starting and operating trip delay
- Panel mounting
- Dimensions: 73H x 75W x 49D mm

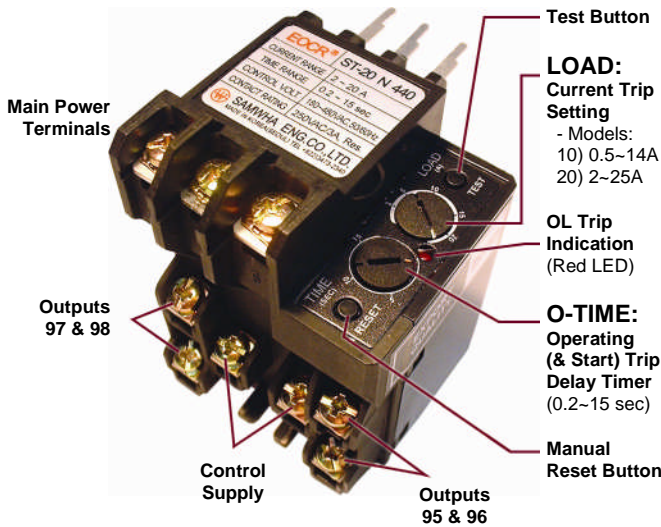

**Model EOST – Definite, Quick Connect**

PART NUMBER	CURRENT RANGE
EOST 104	0.5 ~ 14A
EOST 254	2 ~ 25A

**Applications**

Ideal for switchboard manufacturers due to their compact size directly fitting into contactors. Suitable for replacing older bi-metal overload units (coil circuit must be less than 250Vac).

**Features**

- Economical and compact
- Fits directly into contactors (most makes)
- Single timer for starting and operating trip delay
- Dimensions: 76H x 52W x 75D mm

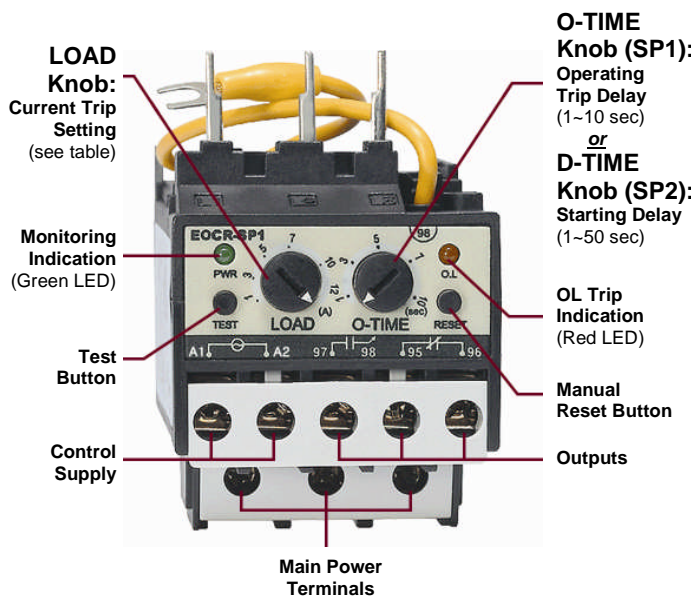

**Model EOSP1/SP2 – MCU, Quick Connect**

PART NUMBER	CURRENT RANGE
EOSP1 022	0.3 ~ 2A
EOSP1 102	1 ~ 12A
EOSP2 022	0.2 ~ 1.2A
EOSP2 102	1 ~ 12A
EOSP2 202	5 ~ 25A

**Applications**

Suitable for replacing older bi-metal overload units (coil circuit must be less than 250Vac).

- Features**
- Compact design
  - Fits directly into IEC or NEMA contactors (consult EIC)
  - Adjustable timer for starting or operating trip delays
  - MCU (microprocessor control unit) based
  - Dimensions: 70H x 47W x 61D mm

**Time Specifications**

Timer Characteristics ..... - SP1: Inverse  
 - SP2: Definite

Operating Delay (O-TIME) ..... - SP1: 1 ~ 10 sec  
 - SP2: 5 sec (fixed)

Starting Delay (D-TIME) ..... - SP1: 10 sec (fixed)  
 - SP2: 1 ~ 50 sec

Notes: ① Cable size maybe a limiting factor for 60A models.

### 3-Phase Sensing Current Relays

#### Summary Table

MODEL		EODS1	EODS2 &3	EOCR-3DM & FDM		EOCR-4E	EGR
Time Characteristics	Definite Time		●	Selectable			●
	Inverse Time	●		Definite or Inverse Time		●	
Protection Functions	Over-Current	●	●	●	●	●	
	Short Circuit					●	
	Under-Current			●	●		
	Ground Fault					●	●
	Phase Loss	●	●	●	●	●	
	Locked Rotor	●	●	●	●		
	Stall			●	●		
	Phase Reverse		●(DS3)	●	●		
Other Features	Phase Unbalance			●	●	●	
	Selectable Alert OP's			●	●		
Technical Specifications	Digital Display			●	●		
	Processor	MCU Based		MCU Based with ASIC Chip		Solid State Circuitry	
	Control Voltage	180 ~ 260V AC (std)		85 ~ 250V AC/DC (std)		110 or 220V AC (std)	
	Output Contacts Mode & Rating	O-Load: 2x SPST		O-Load: 2x SPST Alert: 1x SPST		1x SPST	
		3A @ 250V AC (resistive)				8A/250V AC	3A/250V AC
	Fail Safe Operation	"No Volt Release" (NVR) Protection as standard		Selectable by NVR DIP switch		NVR Protection as standard	
	Trip Indication	LEDs		Digital Display		LEDs	
Reset Method	Manual Reset Button or Electrical (remote) Reset by interrupting power supply (EOCR models – Auto-Reset option also included)						

Notes: PCU: Power Control Unit DCU: Display Control Unit ASIC: Application Specific Integrated Circuit

### Model EODS1/DS2/DS3 – Compact

PART NUMBER	CURRENT RANGE
EODS1 052	0.5 ~ 6A
EODS1 302	3 ~ 30A
EODS2 052 ●	0.5 ~ 6A
EODS2 302 ●	3 ~ 30A
EODS2 602 ●	5 ~ 60A
EODS3 052	0.5 ~ 6A
EODS3 302	3 ~ 30A
EODS3 602	5 ~ 60A

#### Applications

Suitable for general motor overload protection. The 3 models cover applications from pumps, fans and conveyors to mobile plants.

#### Features

- Compact design
- Electronic shear-pin function (DS2 & DS3)
- Separate adjustable starting and operating trip delay timers
- Fail-safe operation (no voltage release)
- MCU (microprocessor control unit) based
- Straight through cabling (terminal kit optional)
- DIN rail mounting
- Dimensions: 70H x 47W x 61D mm

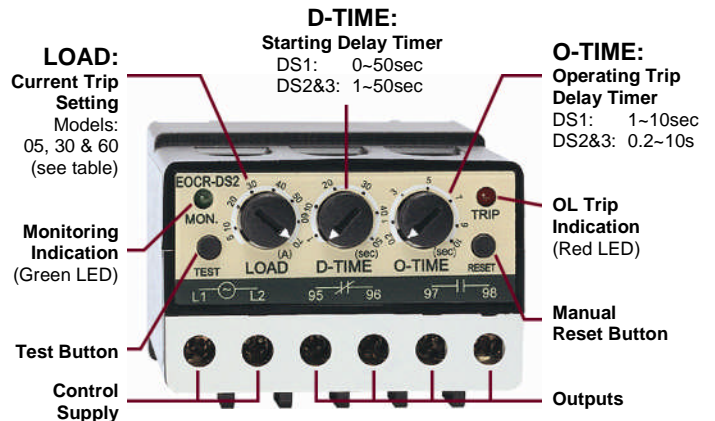

#### Time Specifications

- Time Characteristics ..... - DS1: Inverse  
 - DS2: Definite  
 - DS3: Definite
- Phase Loss Trip ..... Within 4 sec  
 Locked Rotor Trip ..... Just after D-TIME  
 Phase Reversal Trip ..... 0.1 sec (DS3 only)

Notes: ● 24Vac/dc also stocked in the EODS2 model. To order, add a "4" to the end of the part number (eg: EODS2 0524).  
 - Other supply voltages available on request.  
 - Cable size maybe a limiting factor for 60A models.  
 - For ranges over 60A, use EODSx 052 with external CT's.

EOCR-3DM Image:

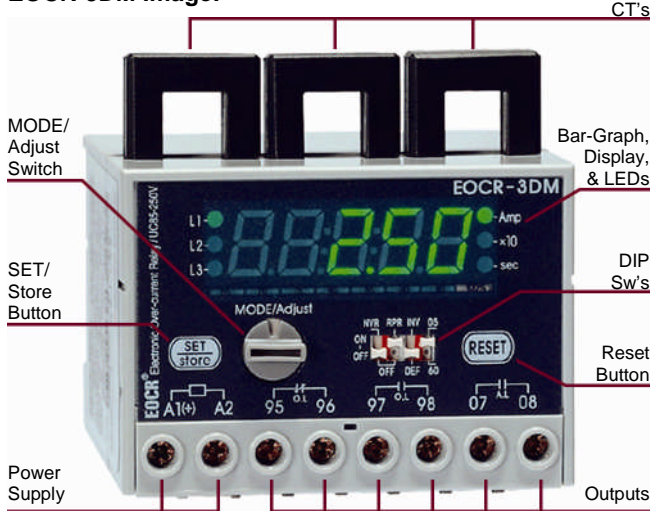

**Display & LED Indications:**

- Display : Shows values for 3-phase current, trip cause, operating hour, etc.
- Bar-Graph : Shows load factor for current setting
- L1 LED : Indicates Line 1 on display (phase R or A)
- L2 LED : Indicates Line 2 on display (phase S or B)
- L3 LED : Indicates Line 3 on display (phase T or C)
- Amp LED : Indicates value shown is in amperes
- x10 LED : Indicates value is to be multiplied by 10
- sec LED : Indicates value shown is in seconds

**DIP Switch Settings:**

- SW#1 – NVR : Off / On – No Voltage Release option
- SW#2 – RPR : Off / On – Reverse Phase Relay option
- SW#3 – INV / DEF : Inverse or Definite time option
- SW#4 – 05 / 60 : 05 or 60 current range option

EOCR-FDM Image:

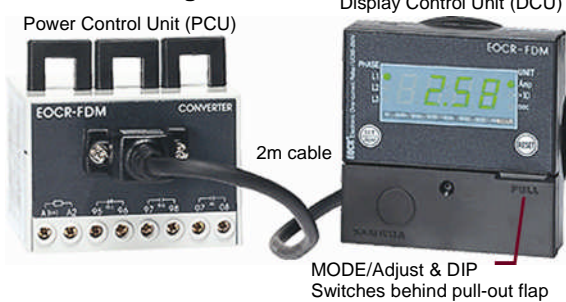

**Model EOCR-3DM/FDM – Digital Display**

PART NUMBER	CURRENT RANGE																												
EOCR-3DM EOCR-FDM	05 or 60 setting - see table below																												
<b>Applications</b> Will replace almost any existing overload (coil circuit must be less than 250Vac).																													
<b>Features</b>																													
<ul style="list-style-type: none"> <li>• Allows high inertia starting</li> <li>• Built-in ammeter / display</li> <li>• Bar-graph monitoring on impending overload trip</li> <li>• Multiple protection</li> <li>• Easy setting using a pulse rotary switch</li> <li>• MCU (microprocessor control unit) based</li> <li>• ASIC (application specific integrated circuit) inside</li> <li>• Dimensions:                             <ul style="list-style-type: none"> <li>- EOCR-3DM: 69H x 70W x 71D mm</li> <li>- EOCR-FDM: PCU: 69H x 70W x 71D mm DCU: 72H x 72W x 39D mm</li> </ul> </li> </ul>																													
<b>Mode Settings Available:</b>																													
<ul style="list-style-type: none"> <li>oc : Over-Current setting (Amps)</li> <li>dt : Starting delay time setting (sec)</li> <li>ot : Over-Current trip delay time setting (sec)</li> <li>AL : Alert percentage setting (%)</li> <li>ALo : Alert output type setting (Flicker/Hold/Aux)</li> <li>uc : Under-Current setting (Amps)</li> <li>ut : Under-Current trip delay time setting (sec)</li> <li>rt : Reset method options (manual only, electrical, or automatic)</li> <li>-trh : Total running hour display (hr)</li> <li>rh : Running hour setting (hr)</li> <li>--rh : Running hour setting (hr)</li> <li>Lc : Locked rotor current setting (multiple)</li> <li>St : Stall trip delay time setting (sec)</li> <li>ct : Primary current of CT setting (various)</li> <li>FAULT : Cause of trip confirmation</li> <li>TEST : Self-test and function check of sequence after setup</li> </ul>																													
<b>Alert Indication:</b>																													
<table border="1"> <thead> <tr> <th>ALO Setting</th> <th>Condition</th> <th>Motor Stop</th> <th>Motor Starting</th> <th>Normal Running</th> <th>Exceeds Alert Setting</th> <th>TRIP</th> </tr> </thead> <tbody> <tr> <td>Flicker "F"</td> <td></td> <td></td> <td>     </td> <td>     </td> <td>     </td> <td>     </td> </tr> <tr> <td>Hold "H"</td> <td></td> <td></td> <td></td> <td></td> <td>     </td> <td></td> </tr> <tr> <td>Aux "A"</td> <td></td> <td></td> <td></td> <td></td> <td></td> <td>     </td> </tr> </tbody> </table>		ALO Setting	Condition	Motor Stop	Motor Starting	Normal Running	Exceeds Alert Setting	TRIP	Flicker "F"							Hold "H"							Aux "A"						
ALO Setting	Condition	Motor Stop	Motor Starting	Normal Running	Exceeds Alert Setting	TRIP																							
Flicker "F"																													
Hold "H"																													
Aux "A"																													

Function	Current Setting Range	Time Setting Range	Notes
Over-Current	oc	ot	- 05 or 60 setting range selected by DIP SW#4 - Definite or Inverse selected by DIP SW#3
	05 setting : 0.5 ~ 10A 60 setting : 5 ~ 60A Under 0.5A : conductor looping thru CTs Over 60A : combination external CT	Definite: 0.2 ~ 30s Inverse: 1 ~ 30s	
Under-Current	uc	ut	Definite time characteristic
Phase Loss	-		Within 3s – fixed
Reverse Phase	-		0.1s – fixed
Unbalance	When current unbalance ≥ 50%		Within 8s – fixed
Lock (Jam)	Stalled	St	Stall and locked rotor functions become disabled if Inverse mode is selected by DIP SW#3
	Locked	Lc	
Starting Delay	-	dt	When set to OFF, the trip time corresponds to Inverse T-C curve

**Model EOGR-4E – Multifunction Inverse**

PART NUMBER		CURRENT RANGE		
EOGR-4E		0.5 ~ 6.5A		
<p><b>Applications</b> Suitable for high tension motors and substation protection.</p> <p><b>Features</b></p> <ul style="list-style-type: none"> <li>Adjustable ground fault protection</li> <li>Adjustable instantaneous (short circuit) overcurrent protection</li> <li>Phase loss and phase unbalance protection</li> <li>Fail-safe operation (no voltage release)</li> <li>DIN rail mounting</li> <li>Dimensions: 68H x 70W x 66D mm</li> </ul>				
FUNCTION	OVER CURRENT	SHORT CIRCUIT	PHASE LOSS	GROUND FAULT
Current Range	0.5 ~ 6.5A	500 ~ 2000%	Unbalance Phase > 60%	0.1 ~ 1A
Trip Time & Character	0.5 ~ 5 sec Inverse	0.03 sec Instantaneous	0.5 sec Definite	0.1 ~ 1 sec Definite

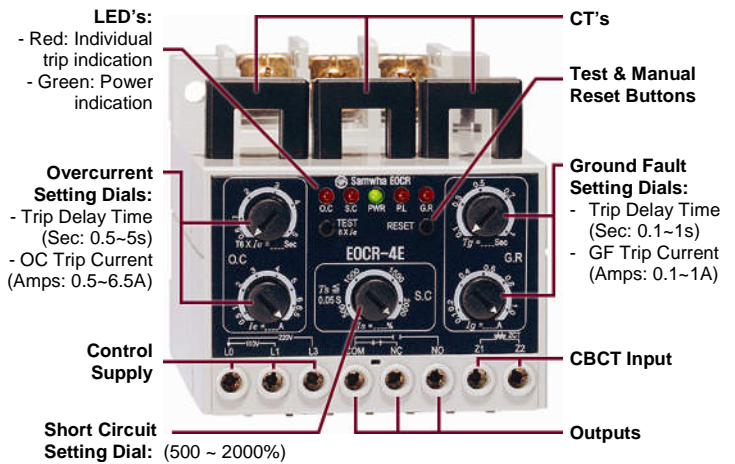

**Model EGR – Electronic Ground Fault Relay**

PART NUMBER		CURRENT RANGE	
EGR 05		50 ~ 500 mA	
EGR 10		100 ~ 1000 mA	
EGR 20		200 ~ 2500 mA	
<p><b>Applications</b> Designed to detect mA signals from CBCT and compare with preset trip level of earth leakage current. Suitable for protecting non-grounded systems of 3kV and 70kV, and resistance and reactor ground systems of 60kV and 70kV, and similar application.</p> <p><b>Features</b></p> <ul style="list-style-type: none"> <li>Adjustable ground fault protection</li> <li>Fail-safe operation (no voltage release)</li> <li>Panel or DIN rail mounting</li> <li>Dimensions: 71H x 70W x 53D mm</li> </ul>			

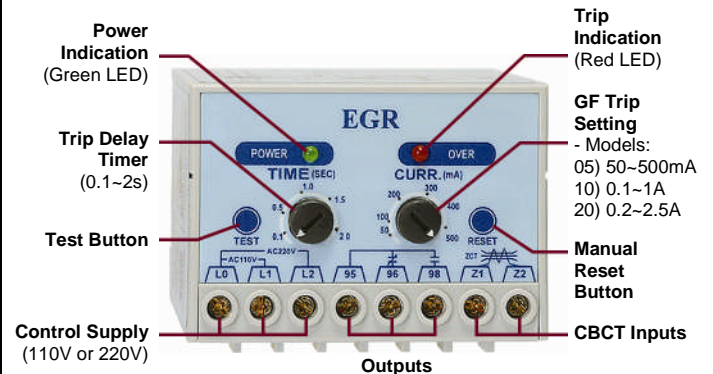

**CT Selection**

<p><b>2CT &amp; 3CT</b></p> <ul style="list-style-type: none"> <li>Definite Time Devices</li> <li>Measuring Class 1.0</li> <li>Panel Mount</li> </ul>		<p><b>SR3CT (3x CT set)</b></p> <ul style="list-style-type: none"> <li>Inverse Time Devices</li> <li>Protection Class 10P10</li> <li>Panel and DIN Mount</li> </ul>		<p><b>ZCT (CBCT type)</b></p> <ul style="list-style-type: none"> <li>Ground Fault Protection Devices</li> <li>Detect Zero Phase Current</li> <li>Panel Mount</li> </ul>
Current Ratio	2CT PART No	3CT PART No	SR3CT PART No	ZCT PART No
100 : 5A	2CT100SQ	3CT100SQ	SR3CT100	Hole dimensions in mm: <b>ZCT32 (32mm)</b> <b>ZCT78 (78mm)</b> (other hole sizes available)
150 : 5A	-	-	SR3CT150	
200 : 5A	2CT200SQ	3CT200SQ	SR3CT200	
300 : 5A	2CT300SQ	3CT300SQ	SR3CT300	
400 : 5A	-	3CT400SQ	SR3CT400	