

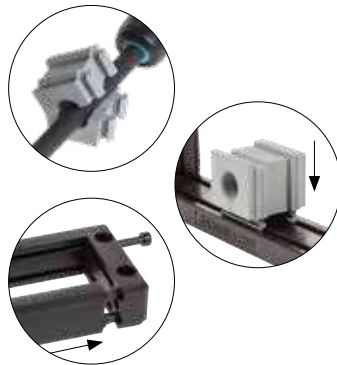

Model	Code	Some possible configurations	Cut-out [mm]	Pcs /pack
DES 16	1731010016		86 x 39	1 / 10
Upon request:	1731991020	Set of 4 mounting screws in AISI304 with Black Dacromet finishing		1 / 10

## Splittable frame for pre-terminated cables

- ▶ Multiple possible configurations in one frame size
- ▶ Frame screws in AISI304 Stainless Steel
- ▶ Integrated gasket
- ▶ Strain relief according to EN 62444
- ▶ Sturdy construction IK10
- ▶ Up to IP66

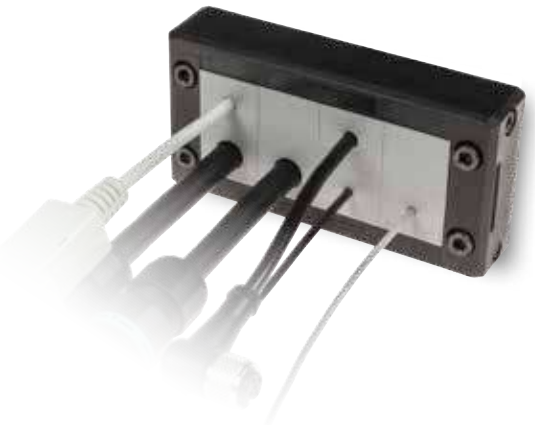

The DES 16 cable entry system consists of a splittable frame designed to accommodate small (SPP), multiple (X) or large (SPG) inserts for cables in the same frame. Future cable size changes can be easily accommodated.

Thanks to the robust construction, the DES 16 is a long lasting product.

### Technical data

**Material:** PP+GF

**Flammability:** self-extinguishing acc. to UL94-V0

**Temperature:** -40°C... +155°C (static)

**Features:** halogens and silicones free

### Related products

- Inserts SPG and SPG M
- Inserts SPP and SPP K
- Inserts SPP 2x
- Inserts SPP 4x
- Flap frame

Hydraulic punch driver HY360

### Dimensions [mm]

