

MODULAR CIRCUIT BREAKERS FOR CIRCUIT PROTECTION

MCB - MTC - MT - MTHP

Technical data

| TYPE | | MTC | | | MT | | |
|---|---------------------|------------------------------------|---------------------|----------------------------|-----------------------|-------------------------------|-------------------------------|
| | | MTC45 | MTC60 | MTC100 | MT 45 | MT 60 | |
| | | | | | | | |
| Rated current (In) | (A) | 2-32 | 6-32 | 6-32 | 6-40 | 1-63 | |
| Utilization category | | A | A | A | A | A | |
| Rated operational voltage (Ue) | (V) | 230/400 - 240/415 | 230/400 - 240/415 | 230 - 240 | 230/400 - 240/415 | 230/400 - 240/415 | |
| Minimum operating voltage (Ue min) | (V) | 12 AC/DC | 12 AC/DC | 12 AC/DC | 12 AC/DC | 12 AC/DC | |
| Maximum operating voltage (Ue max) | (V) | 440 AC/ 220 DC | 440 AC/ 220 DC | 253 AC/ 110 DC | 440 AC/ 220 DC | 440 AC/ 220 DC | |
| Insulation voltage (Ui) | (V) | 500 | 500 | 500 | 500 | 500 | |
| Rated frequency | (Hz) | 50 / 60 | 50 / 60 | 50 / 60 | 50 / 60 | 50 / 60 | |
| Rated impulse withstand voltage (Uimp) | (kV) | 4 | 4 | 4 | 4 | 4 | |
| Overvoltage category: | | III | | | III | | |
| Number of poles | | 1 1+N,2 3,4 | 1+N,2 3,4 | 1+N,2 | 1,1+N 2,3,4 | 1, 1+N 2,3,4 | |
| Energy limiting class (B and C curve): | | 3 3 3 | 3 | 3 (≤16A) 1 (>16A) | 3 3 | 3 3 | |
| Breaking capacity | | | | | | | |
| Alternating current | IEC/EN 60898-1 | Icn (A) | 4500 | 6000 ⁽¹⁾ 6000 | 10000 ⁽¹⁾ | 4500 | 6000 |
| | | Ics (A) | 1 Icn | 1 Icn | 0.75 Icn | 1 Icn | 1 Icn |
| | | Icu 230/240 V (kA) | 4.5 6 6 | 7.5 7.5 | 10 | 4.5 6 | 10 20 |
| | IEC/EN 60947-2 | Icu 400/415 V (kA) | - - 4.5 | - 6 | - | - 6 | - 10 |
| | | Ics (kA) | 100% Icu | 100% Icu | 75% Icu | 100% Icu | 75% Icu |
| Direct current | IEC/EN 60947-2 | Icu (1 pole) 50 V (kA) | 6 | 10 | - | 6 | 10 |
| | | Ics (kA) | 6 | 10 | - | 6 | 10 |
| | | Icu (2 poles in series) 110 V (kA) | 6 | 10 | 10 (15 at 50V) | 6 | 10 |
| | | Ics (kA) | 6 | 10 | 10 (15 at 50V) | 6 | 6 |
| | | Icu (4 poles in series) 220 V (kA) | 4.5 | 6 | - | 4.5 | 10 |
| | | Ics (kA) | 4.5 | 6 | - | 4.5 | 10 |
| Wiring | cable section (mm²) | rigid | ≤ 1x16 - ≤ 1x10+1x6 | ≤ 1x16 - ≤ 1x10+1x6 | ≤ 1x16 - ≤ 1x10+1x6 | ≤ 1x35 - ≤ 2x16 - ≤ 1x16+2x10 | ≤ 1x35 - ≤ 2x16 - ≤ 1x16+2x10 |
| | flexible | | ≤ 1x10 - ≤ 2x6 | ≤ 1x10 - ≤ 2x6 | ≤ 1x10 - ≤ 2x6 | ≤ 1x35 - ≤ 2x16 - ≤ 1x16+2x10 | ≤ 1x35 - ≤ 2x16 - ≤ 1x16+2x10 |
| Screwdriver suggested: | | PZ2 | PZ2 | PZ2 | PZ2 | PZ2 | |
| Electrical endurance: | | 10000 | 10000 | 10000 | 10000 | 10000 | |
| Mechanical endurance: | | 20000 | 20000 | 20000 | 20000 | 20000 | |
| Max. no. of usable modular accessories: | | 2 | 2 | 2 | 2 | 2 | |
| Upline/downline power supply: | | yes | yes | yes | yes | yes | |
| ON/OFF status displayed: | | yes | yes | yes | yes | yes | |
| Mounting position: | | any | any | any | any | any | |
| Type of residual current device: | | - | - | - | Add-on RCD BD | Add-on RCD BD | |
| Rated tightening torque: | (Nm) | 1.2 | 1.2 | 1.2 | 2 | 2 | |
| Degree of protection: | terminals | IP20 | IP20 | IP20 | IP20 | IP20 | |
| | front | IP40 | IP40 | IP40 | IP40 | IP40 | |
| Pollution degree: | | 2 | 2 | 2 | 2 | 2 | |
| Tropicalization: | | 55°C - RH 95% | 55°C - RH 95% | 55°C - RH 95% | 55°C - RH 95% | 55°C - RH 95% | |
| Reference temperature: | (°C) | 30 | 30 | 30 | 30 | 30 | |
| Operating temperature: | (°C) | -25 +60 | -25 +60 | -25 +60 | -25 +60 | -25 +60 | |
| Stocking temperature: | (°C) | -40 +70 | -40 +70 | -40 +70 | -40 +70 | -40 +70 | |
| Double connection (cable+fork busbar) | | no | no | no | yes (only downstream) | yes (only downstream) | |
| Weight: | (g) | 135 (per module) | 135 (per module) | 135 (per module) | 145 (per pole) | 145 (per pole) | |
| Tripping characteristic | | C | C B | C | C B | C B D | |
| Rated currents available In: | (A) | - | - | - | - | 1 - - | |
| | | 2 | - | - | - | 2 - - | |
| | | - | - | - | - | 3 - - | |
| | | - | - | - | - | 4 - - | |
| | | 6 | 6 6 | 6 | 6 6 | 6 6 6 | |
| | | 10 | 10 10 | 10 | 10 10 | 10 10 10 | |
| | | 13 | 13 13 | 13 | 13 13 | 13 13 13 | |
| | | 16 | 16 16 | 16 | 16 16 | 16 16 16 | |
| | | 20 | 20 20 | 20 | 20 20 | 20 20 20 | |
| | | 25 | 25 25 | 25 | 25 25 | 25 25 25 | |
| | | 32 | 32 32 | 32 | 32 32 | 32 32 32 | |
| | | - | - | - | 40 40 | 40 40 40 | |
| | | - | - | - | - | 50 50 - | |
| | | - | - | - | - | 63 63 - | |
| | | - | - | - | - | - - - | |
| | | - | - | - | - | - - - | |

⁽¹⁾ Breaking capacity of the single pole Icn=4500A ⁽²⁾ ≤95mm² with reduced connection terminal (width connection < 17mm)

MODULAR CIRCUIT BREAKERS FOR CIRCUIT PROTECTION

| MT | | | | | | | | | | | | MTHP | | | | | | | | | | | |
|-----------------------------|----|-----|-------------------------------|----|------|-------------------------------|----|-----|-------------------------------|----|-----|-------------------------------|----|-----|-------------------------------|----|-----|---|-------|----|---|-----|--|
| MT 100 | | | | | | MT 250 | | | | | | MTHP 160 | | | MTHP 250 | | | | | | | | |
| | | | | | | | | | | | | | | | | | | | | | | | |
| 1-25 | | | 32-63 | | | 6-20 | | | 25 | | | 32-40 | | | 50-63 | | | 63-125 | | | 20-63 | | |
| A | | | A | | | A | | | A | | | A | | | A | | | A | | | A | | |
| 230/400 - 240/415 | | | 230/400 - 240/415 | | | 230/400 - 240/415 | | | 230/400 - 240/415 | | | 230/400 - 240/415 | | | 230/400 - 240/415 | | | 230/400 | | | 230/400 | | |
| 12 AC/DC | | | 12 AC/DC | | | 12 AC/DC | | | 12 AC/DC | | | 12 AC/DC | | | 12 AC/DC | | | 12 AC/DC | | | 12 AC/DC | | |
| 440 AC/220 DC | | | 440 AC/220 DC | | | 440 AC/220 DC | | | 440 AC/220 DC | | | 440 AC/220 DC | | | 440 AC/220 DC | | | 440 AC/220 DC | | | 440 AC/220 DC | | |
| 500 | | | 500 | | | 500 | | | 500 | | | 500 | | | 500 | | | 500 | | | 500 | | |
| 50/60 | | | 50/60 | | | 50/60 | | | 50/60 | | | 50/60 | | | 50/60 | | | 50/60 | | | 50/60 | | |
| 4 | | | 4 | | | 4 | | | 4 | | | 4 | | | 4 | | | 6 | | | 6 | | |
| III | | | III | | | III | | | III | | | III | | | III | | | IV | | | IV | | |
| 1 | 2 | 3,4 | 1 | 2 | 3,4 | 1 | 2 | 3,4 | 1 | 2 | 3,4 | 1 | 2 | 3,4 | 1 | 2 | 3,4 | 1 | 2,3,4 | 1 | 2 | 3,4 | |
| 3 | 3 | 3 | 3 | 3 | 3 | - | - | - | - | - | - | - | - | - | - | - | - | - | - | - | - | - | |
| 10000 | | | 10000 | | | 25000 | | | 20000 | | | 15000 | | | 12500 | | | 10000 | | | 25000 | | |
| 0.75 Icn | | | 0.75 Icn | | | 0.75 Icn | | | 0.75 Icn | | | 0.75 Icn | | | 0.75 Icn | | | 0.75 Icn | | | 0.75 Icn | | |
| 15 | 30 | 25 | 12.5 | 25 | 20 | 25 | 50 | 40 | 20 | 40 | 30 | 15 | 30 | 25 | 15 | 25 | 20 | 16 | 20 | 25 | 50 | 30 | |
| - | 20 | 15 | - | 15 | 12.5 | - | 30 | 25 | - | 25 | 20 | - | 20 | 15 | - | 15 | 15 | 4.5 | 16 | 6 | 25 | 25 | |
| 50% Icu | | | 50% Icu | | | 50% Icu | | | 50% Icu | | | 50% Icu | | | 50% Icu | | | 50% Icu | | | 75% Icu | | |
| 10 | | | 10 | | | 20 | | | 20 | | | 20 | | | 20 | | | 10 | | | 25 | | |
| 10 | | | 10 | | | 15 | | | 15 | | | 15 | | | 15 | | | 10 | | | 20 | | |
| 15 | | | 15 | | | 25 | | | 25 | | | 25 | | | 25 | | | 15 | | | 30 | | |
| 15 | | | 15 | | | 20 | | | 20 | | | 20 | | | 20 | | | 12 | | | 25 | | |
| 15 | | | 15 | | | 25 | | | 25 | | | 25 | | | 25 | | | 15 | | | 25 | | |
| 12 | | | 12 | | | 20 | | | 20 | | | 20 | | | 20 | | | 12 | | | 20 | | |
| 1x35 - . 2x16 - . 1x16+2x10 | | | ≤ 1x35 - ≤ 2x16 - ≤ 1x16+2x10 | | | ≤ 1x35 - ≤ 2x16 - ≤ 1x16+2x10 | | | ≤ 1x35 - ≤ 2x16 - ≤ 1x16+2x10 | | | ≤ 1x35 - ≤ 2x16 - ≤ 1x16+2x10 | | | ≤ 1x35 - ≤ 2x16 - ≤ 1x16+2x10 | | | ≤ 1x70 - ≤ 2x25 - ≤ 2x25+1x10 | | | ≤ 1x70 - ≤ 2x25 - ≤ 2x25+1x10 | | |
| 1x35 - . 2x16 - . 1x16+2x10 | | | ≤ 1x35 - ≤ 2x16 - ≤ 1x16+2x10 | | | ≤ 1x35 - ≤ 2x16 - ≤ 1x16+2x10 | | | ≤ 1x35 - ≤ 2x16 - ≤ 1x16+2x10 | | | ≤ 1x35 - ≤ 2x16 - ≤ 1x16+2x10 | | | ≤ 1x35 - ≤ 2x16 - ≤ 1x16+2x10 | | | ≤ 1x50 ⁽²⁾ - ≤ 2x25 - ≤ 3x16 | | | ≤ 1x50 ⁽²⁾ - ≤ 2x25 - ≤ 3x16 | | |
| PZ2 | | | PZ2 | | | PZ2 | | | PZ2 | | | PZ2 | | | PZ2 | | | PZ2 | | | PZ2 | | |
| 10000 | | | 10000 | | | 10000 | | | 10000 | | | 10000 | | | 10000 | | | 10000 | | | 10000 | | |
| 20000 | | | 20000 | | | 20000 | | | 20000 | | | 20000 | | | 20000 | | | 20000 | | | 20000 | | |
| 2 | | | 2 | | | 2 | | | 2 | | | 2 | | | 2 | | | 2 | | | 2 | | |
| yes | | | yes | | | yes | | | yes | | | yes | | | yes | | | yes | | | yes | | |
| yes | | | yes | | | yes | | | yes | | | yes | | | yes | | | yes | | | yes | | |
| any | | | any | | | any | | | any | | | any | | | any | | | any | | | any | | |
| Add-on RCD BD | | | Add-on RCD BD | | | Add-on RCD BD | | | Add-on RCD BD | | | Add-on RCD BD | | | Add-on RCD BD | | | Add-on RCD BDHP | | | Add-on RCD BDHP | | |
| 2 | | | 2 | | | 2 | | | 2 | | | 2 | | | 2 | | | 3.5 / 3 (terminal) | | | 3.5 / 3 (terminal) | | |
| IP20 | | | IP20 | | | IP20 | | | IP20 | | | IP20 | | | IP20 | | | IP20 | | | IP20 | | |
| IP40 | | | IP40 | | | IP40 | | | IP40 | | | IP40 | | | IP40 | | | IP40 | | | IP40 | | |
| 2 | | | 2 | | | 2 | | | 2 | | | 2 | | | 2 | | | 2 | | | 2 | | |
| 55°C - RH 95% | | | 55°C - RH 95% | | | 55°C - RH 95% | | | 55°C - RH 95% | | | 55°C - RH 95% | | | 55°C - RH 95% | | | 55°C - RH 95% | | | 55°C - RH 95% | | |
| 30 | | | 30 | | | 30 | | | 30 | | | 30 | | | 30 | | | 30 | | | 30 | | |
| -25 +60 | | | -25 +60 | | | -25 +60 | | | -25 +60 | | | -25 +60 | | | -25 +60 | | | -25 +60 | | | -25 +60 | | |
| -40 +70 | | | -40 +70 | | | -40 +70 | | | -40 +70 | | | -40 +70 | | | -40 +70 | | | -40 +70 | | | -40 +70 | | |
| yes (only downstream) | | | yes (only downstream) | | | yes (only downstream) | | | yes (only downstream) | | | yes (only downstream) | | | yes (only downstream) | | | no | | | no | | |
| 145 (per pole) | | | 145 (per pole) | | | 145 (per pole) | | | 145 (per pole) | | | 145 (per pole) | | | 145 (per pole) | | | 250 (per pole) | | | 250 (per pole) | | |
| C | | B | | D | | C | | | | | | C | | D | | C | | | | | | | |
| - | | - | | 1 | | - | | | | | | - | | - | | - | | | | | | | |
| - | | - | | 2 | | - | | | | | | - | | - | | - | | | | | | | |
| - | | - | | 3 | | - | | | | | | - | | - | | - | | | | | | | |
| - | | - | | 4 | | - | | | | | | - | | - | | - | | | | | | | |
| 6 | | 6 | | 6 | | 6 | | | | | | 6 | | 6 | | 6 | | | | | | | |
| 10 | | 10 | | 10 | | 10 | | | | | | 10 | | 10 | | 10 | | | | | | | |
| 13 | | 13 | | 13 | | - | | | | | | - | | - | | - | | | | | | | |
| 16 | | 16 | | 16 | | 16 | | | | | | 16 | | 16 | | 16 | | | | | | | |
| 20 | | 20 | | 20 | | 20 | | | | | | 20 | | 20 | | 20 | | | | | | | |
| 25 | | 25 | | 25 | | 25 | | | | | | 25 | | 25 | | 25 | | | | | | | |
| 32 | | 32 | | 32 | | 32 | | | | | | 32 | | 32 | | 32 | | | | | | | |
| 40 | | 40 | | 40 | | 40 | | | | | | 40 | | 40 | | 40 | | | | | | | |
| 50 | | 50 | | - | | 50 | | | | | | 50 | | 50 | | 50 | | | | | | | |
| 63 | | 63 | | - | | 63 | | | | | | 63 | | 63 | | 63 | | | | | | | |
| - | | - | | - | | - | | | | | | 80 | | 80 | | - | | | | | | | |
| - | | - | | - | | - | | | | | | 100 | | 100 | | - | | | | | | | |
| - | | - | | - | | - | | | | | | 125 | | - | | - | | | | | | | |

For technical information contact the Technical Assistance Service or visit gewiss.com

CHARACTERISTICS OF THE NEW KINEMATIC MECHANISM OF THE MTC COMPACT CIRCUIT BREAKERS

The position of the releases on the front, with magnetic turns and opposing arc chute chambers, allows a notable reduction in arc time and short-circuit strain on the mechanism. It has therefore been possible to halve the system and lighten the mechanism, which has short pre-arc times thanks to the reduced energy. The new mechanism has been sized and optimised by means of a sophisticated planning, engineering and testing programme.

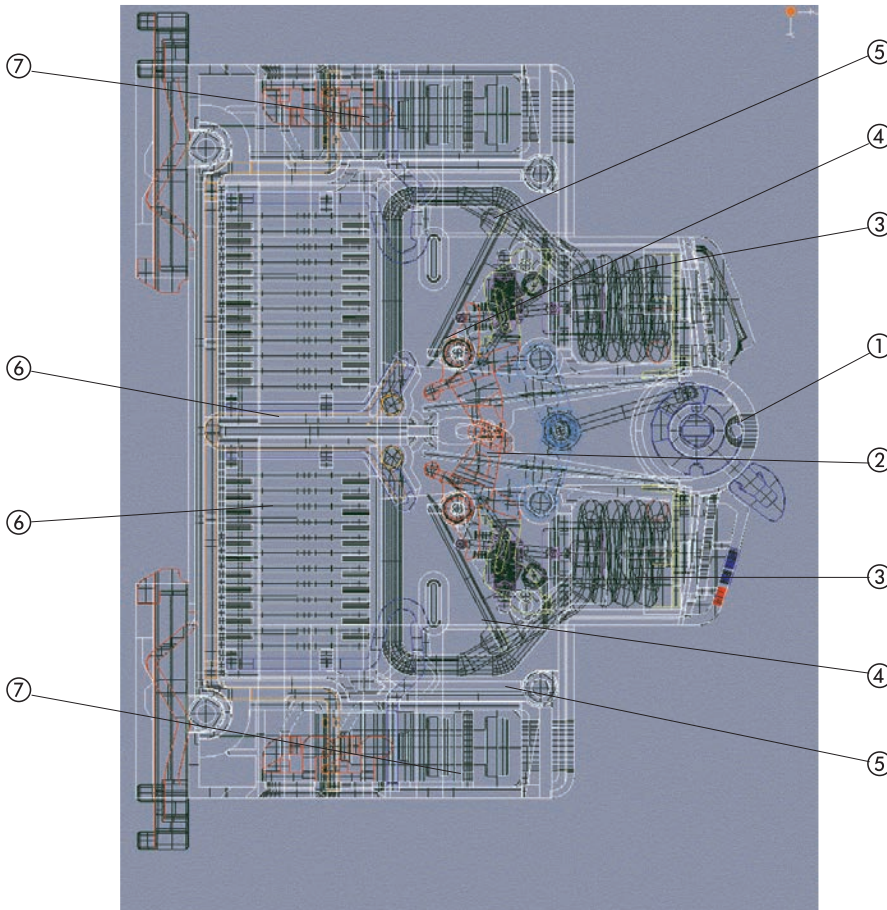

- ① Manual control lever with a position coherent with the contacts, allowing the circuit breaker to be used as a switch disconnecter (in compliance with Standard CEI 64-8)
- ② Toggle joint tripping mechanism with tripping accelerator for short-circuit condition
- ③ Electromagnets for instantaneous short-circuit tripping
- ④ Silver-graphite contacts to maintain electrical characteristics over time
- ⑤ Magnetic turns in the arc chute chambers
Arc chute chambers with 12 reeds in a ferromagnetic material
- ⑥ Shell-type terminals with anti-loosening
- ⑦ tightening system

POWER LOSS VALUES AND TEMPERATURE PERFORMANCE

MTC 45 - 60 - 100 Compact miniature circuit breakers

General characteristics

The MTC compact miniature circuit breakers are characterised by the reduced overall dimensions they occupy in the board, and their full modularity with electrical auxiliaries and modular accessories. It is therefore possible to position all the equipment necessary to protect and control the service electrical system centrally, in small spaces. The innovations are based on a new kinematic mechanism for activating the circuit breaker (with a world-wide Gewiss patent) which helps to increase normal performance while reducing the occupied overall dimensions by 50%. This new device makes it possible to include a bipolar circuit breaker in a single 18mm module, with both poles protected by both magnetic and thermal release.

Temperature performance

In plant engineering situations where the ambient temperature is higher than the standard 30°C reference temperature, the circuit breakers may be subject to untimely tripping, i.e. inappropriate switch-off, because the rise in temperature is interpreted as overcurrent. In fact ambient temperature affects the initial deformation of the bimetal; at a temperature above 30°, the thermal release intervenes more quickly, acting like a relay with a lower rated current.

It is therefore imperative to take into consideration the temperature performance of the rated current if the circuit breaker is installed in a place with a temperature above 30°. The following tables show the max. operating currents corresponding to the different temperatures.

| MTC 45 - 60 - 100 COMPACT MINIATURE CIRCUIT BREAKERS | | | | | | |
|--|-------------|------|------|------|------|------|
| In (A) | Temperature | | | | | |
| | 10°C | 20°C | 30°C | 40°C | 50°C | 60°C |
| 2 | 2.1 | 2.05 | 2 | 1.9 | 1.8 | 1.55 |
| 6 | 7.2 | 6.6 | 6 | 5.7 | 5.3 | 5 |
| 10 | 11.8 | 10.8 | 10 | 9.6 | 9.1 | 8.6 |
| 13 | 15 | 14 | 13 | 12.4 | 11.7 | 11 |
| 16 | 18.2 | 17.2 | 16 | 15.2 | 14.3 | 13.4 |
| 20 | 22.8 | 21.4 | 20 | 19.5 | 18.9 | 18.4 |
| 25 | 28.5 | 26.8 | 25 | 24 | 23 | 22 |
| 32 | 36.5 | 34.2 | 32 | 30.8 | 29.5 | 28 |

Power loss per pole

The following table shows the power loss values for the MTC miniature circuit breakers, so you can check the overtemperature values in the board in relation to Standards EN 60439 and CEI 17 - 43. You can also check whether the power loss of the devices is lower than - or equal to - the level that the enclosure is able to disperse, in accordance with Standards CEI 23 - 49 and CEI 23 - 51.

| MTC 45 - 60 - 100 COMPACT MINIATURE CIRCUIT BREAKERS | | | | | | | | | | | | | | | | |
|--|------|------|------|------|------|------|------|------|------|------|------|------|------|-----|------|------|
| In (A) | 2 | | 6 | | 10 | | 13 | | 16 | | 20 | | 25 | | 32 | |
| | Pole | N | Pole | N | Pole | N | Pole | N | Pole | N | Pole | N | Pole | N | Pole | N |
| R (mΩ) | 450 | 1.07 | 29.4 | 2.6 | 20.3 | 2.6 | 14.2 | 2.6 | 8.7 | 2.6 | 5.7 | 2.6 | 5.3 | 2.6 | 3.4 | 2.6 |
| P (W) | 1.8 | 0.04 | 1.06 | 0.09 | 2.03 | 0.26 | 2.4 | 0.44 | 2.22 | 0.67 | 2.27 | 1.04 | 3.34 | 2 | 3.45 | 2.66 |

MODULAR CIRCUIT BREAKERS FOR CIRCUIT PROTECTION

POWER LOSS VALUES AND TEMPERATURE PERFORMANCE

MT 45 - MT 60 - MT 100 - MT 250 Miniature circuit breakers

General characteristics

Thanks to a wide range and excellent performance, the MT miniature circuit breakers allow the creation of electrical systems in which the use of MTCs alone would be insufficient.

The MT range, with rated current from 1 to 63A, characteristics B, C and D, and a breaking capacity of 6, 10 and 25 kA, satisfies all installation needs in the commercial, advanced commercial and industrial sectors. Thanks to the full modularity with the residual current devices, electrical auxiliaries and modular accessories, the MT range guarantees the optimum solution for every plant engineering context.

| MT 45 - MT 60 - 100 - 250 TEMPERATURE PERFORMANCE | | | | | | |
|---|------------------|------|------|------|------|-------|
| In (A) | Temperature (°C) | | | | | |
| | 15 | 20 | 30 | 40 | 50 | 60 |
| 1 | 1.07 | 1.04 | 1.00 | 0.97 | 0.93 | 0.90 |
| 2 | 2.14 | 2.07 | 2.00 | 1.93 | 1.86 | 1.79 |
| 3 | 3.21 | 3.11 | 3.00 | 2.90 | 2.79 | 2.69 |
| 4 | 4.28 | 4.14 | 4.00 | 3.86 | 3.72 | 3.58 |
| 6 | 7 | 6.67 | 6.00 | 5.52 | 4.84 | 3.96 |
| 10 | 11.2 | 10.8 | 10.0 | 8.9 | 7.95 | 7.16 |
| 13 | 14.4 | 13.9 | 13.0 | 11.9 | 10.9 | 10 |
| 16 | 17.6 | 17.1 | 16.0 | 14.9 | 13.9 | 12.8 |
| 20 | 22 | 21.3 | 20.0 | 17.8 | 16.1 | 15.1 |
| 25 | 28.2 | 27.1 | 25.0 | 23.4 | 21.3 | 18.8 |
| 32 | 37 | 35.3 | 32.0 | 30.8 | 27.8 | 23.1 |
| 40 | 45 | 43.3 | 40.0 | 34.8 | 30 | 28 |
| 50 | 57.5 | 55 | 50.0 | 46.7 | 42.1 | 36.3 |
| 63 | 70 | 67.7 | 63.0 | 59.9 | 52.7 | 41.25 |

| MT 45 - MT 60 - 100 - 250 POWER LOSS PER POLE | | | | | | |
|---|-------------------------|--------|-------|--------|-------|--------|
| In (A) | Tripping characteristic | | | | | |
| | B | | C | | D | |
| | P (W) | R (mΩ) | P (W) | R (mΩ) | P (W) | R (mΩ) |
| 1 | - | - | 2.20 | 2200 | - | - |
| 2 | - | - | 2.70 | 675 | - | - |
| 3 | - | - | 2.30 | 256 | - | - |
| 4 | - | - | 2.20 | 138 | - | - |
| 6 | 1.42 | 39 | 1.42 | 39 | 0.80 | 22 |
| 10 | 2.13 | 21 | 2.13 | 21 | 1.20 | 12 |
| 13 | 2.1 | 12.4 | 2.1 | 12.4 | 1.3 | 7.7 |
| 16 | 2.80 | 11 | 2.80 | 11 | 1.60 | 6.3 |
| 20 | 2.56 | 6.4 | 2.56 | 6.4 | 2.10 | 5.3 |
| 25 | 3.10 | 5 | 3.10 | 5 | 2.00 | 3.2 |
| 32 | 3.00 | 2.9 | 3.00 | 2.9 | 2.40 | 2.4 |
| 40 | 3.10 | 1.9 | 3.10 | 1.9 | 2.70 | 1.7 |
| 50 | 3.87 | 1.5 | 3.87 | 1.5 | - | - |
| 63 | 4.51 | 1.2 | 4.51 | 1.2 | - | - |

Note: power loss values are suitable also for neutral of 1P+N versions.

MTHP 160 - MTHP 250 High performance miniature circuit breakers

General characteristics

Thanks to a wide range and excellent performance, the MTHP miniature circuit breakers allow the creation of electrical systems in which the use of MTCs and MTs alone would be insufficient. The MTHP range, with rated current from 20 to 125A, characteristics C and D, and a breaking capacity of 10 and 25 kA, satisfies all installation needs in the commercial, advanced commercial and industrial sectors. Thanks to the full modularity with the residual current devices, electrical auxiliaries and modular accessories, the MTHP range guarantees the optimum solution for every plant engineering context.

| MTHP 160 - 250 TEMPERATURE PERFORMANCE | | | | | |
|--|-------------|------|------|------|------|
| In (A) | Temperature | | | | |
| | 20°C | 30°C | 40°C | 50°C | 60°C |
| 20 | 21 | 20 | 17.5 | 16 | 15 |
| 25 | 26 | 25 | 24 | 22 | 19 |
| 32 | 35 | 32 | 30 | 28 | 23 |
| 40 | 42 | 40 | 35 | 33 | 28 |
| 50 | 55 | 50 | 47 | 42 | 36 |
| 63 | 66 | 63 | 59 | 53 | 48 |
| 80 | 85 | 80 | 75 | 70 | 63 |
| 100 | 107 | 100 | 93 | 87 | 78 |
| 125 | 135 | 125 | 115 | 107 | 97 |

| MTHP 160 - 250 POWER LOSS PER POLE | | | | | | | | | |
|------------------------------------|----------------|-----|-----|-----|-----|-----|-----|-----|-----|
| In (A) | 20 | 25 | 32 | 40 | 50 | 63 | 80 | 100 | 125 |
| | Power loss (W) | | | | | | | | |
| MTHP 250 | 2.8 | 2.7 | 3.1 | 3.5 | 4.2 | 5.6 | - | - | - |
| MTHP 160 | - | - | - | - | - | 5.6 | 5.6 | 7.4 | 11 |

MODULAR CIRCUIT BREAKERS FOR CIRCUIT PROTECTION

TRIPPING CHARACTERISTICS IN ALTERNATING CURRENT (EN 60898)

MTC 45 - 60 - 100 Characteristic C
 MT 45 - MT 60 - 100 - 250 Characteristic C
 MTHP 160 - 250 Characteristic C

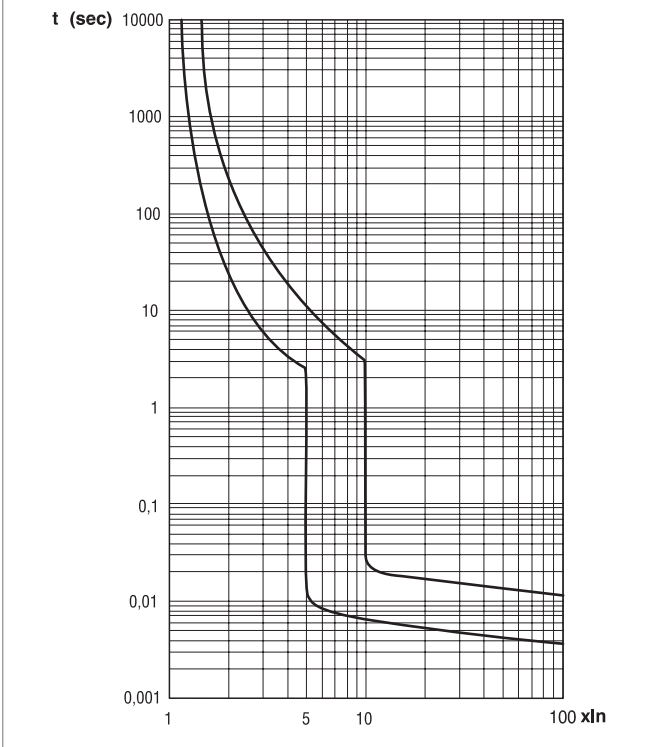

MT 45 - MT 60 - 100 Characteristic B
 MTC 60 Characteristic B

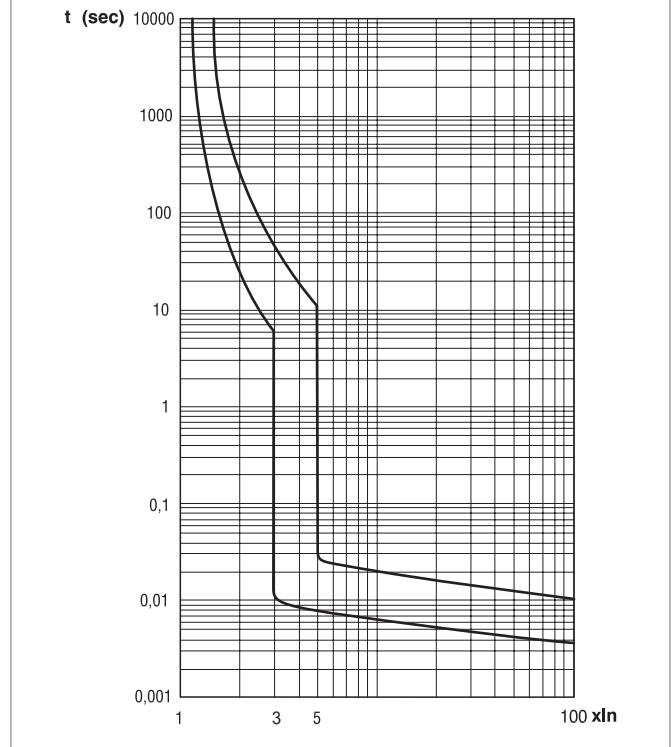

MT 60 - 100 Characteristic D
 MTHP 160 Characteristic D

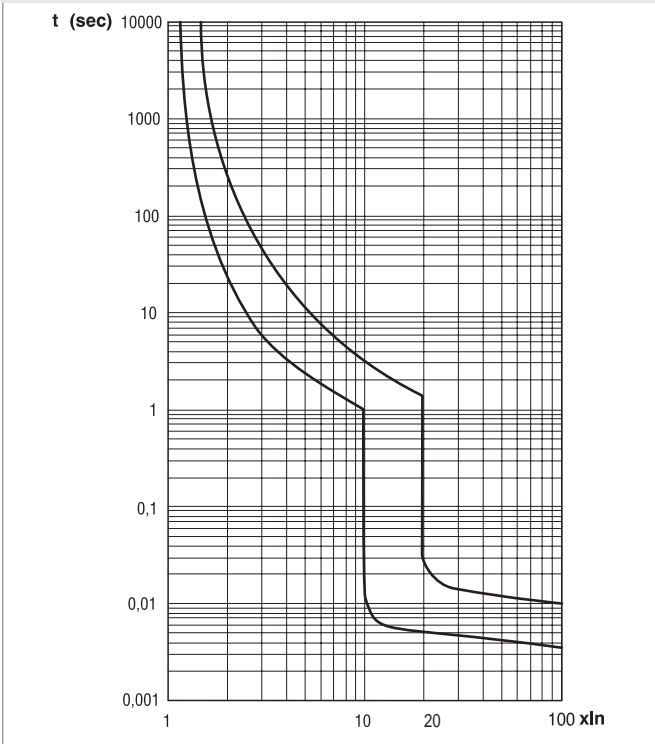

| Tripping characteristic | B | C | D |
|-------------------------|----------------|-----------------|-----------------|
| In | from 6 to 63 A | from 1 to 125 A | from 6 to 100 A |
| Thermal release | | | |
| Inf | 1,13 In | 1,13 In | 1,13 In |
| If | 1,45 In | 1,45 In | 1,45 In |
| t | < 1 h | < 1 h | < 1 h |
| Magnetic release | | | |
| Inf | 3 In | 5 In | 10 In |
| If | 5 In | 10 In | 20 In |
| t | instantaneous | instantaneous | instantaneous |

In = rated current
 Inf = conventional non-tripping current
 If = conventional tripping current
 t = tripping time

B tripping curve: tripping characteristic for the protection of electrical resistive loads (for example: heating) and very long electrical distribution lines.

C tripping curve: tripping characteristic for the protection of general electrical resistive or slight inductive loads (for example: fluorescent lamps).

D tripping curve: tripping characteristic for the protection of electrical heavy inductive loads or high starting currents (for example: electrical engines).

SPECIFIC LET-THROUGH ENERGY CHARACTERISTICS - MTC MODULAR COMPACT CIRCUIT BREAKERS

MTC 45 - 1P+N, 2P - 230V versions

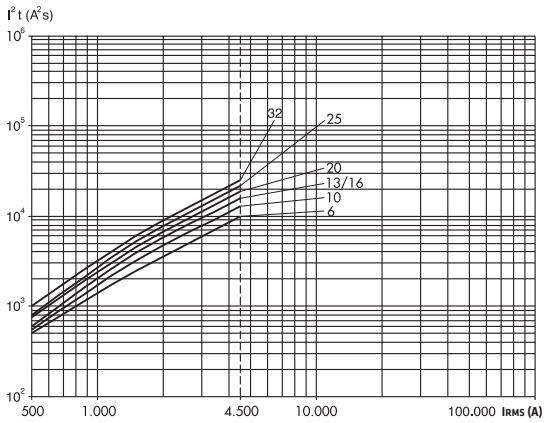

MTC 45 - 1P - 230V and 3P,4P - 230/400V versions

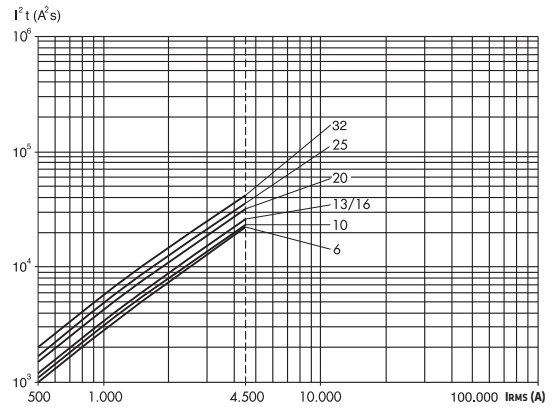

MTC 60 - 1P+N, 2P - 230V versions

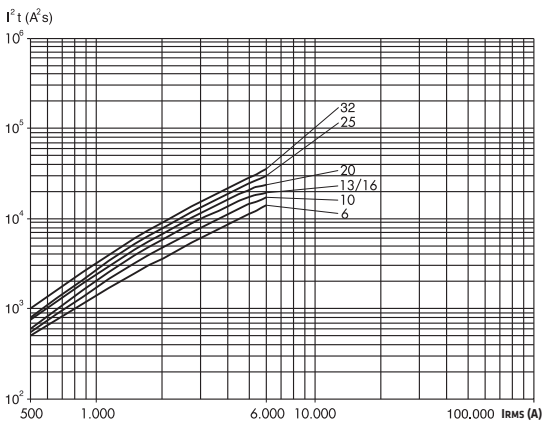

MTC 60 - 3P,4P - 230/400V versions

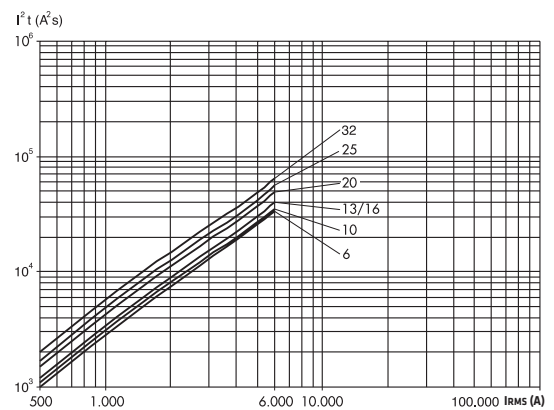

MTC 100 - 1P+N, 2P - 230V versions

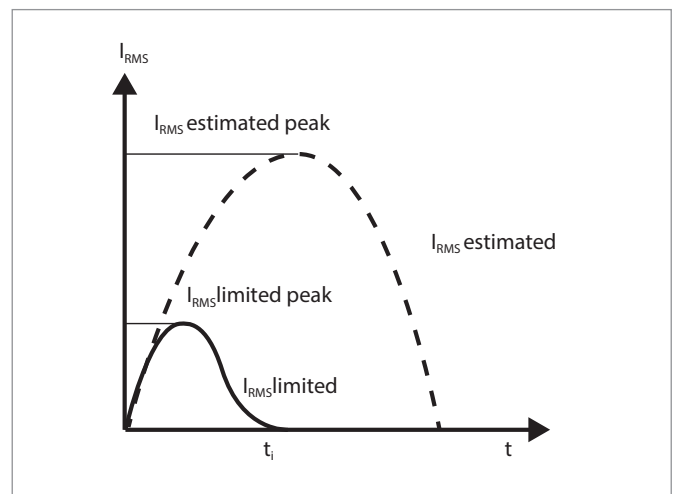
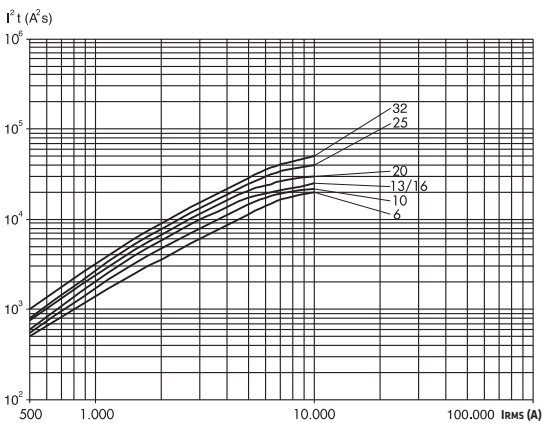

The curves above give the values of the specific let-through energy in relation to the short-circuit current expressed in A. Every curve refers to each rated current value of circuit breaker.

SPECIFIC LET-THROUGH ENERGY CHARACTERISTICS - MT 45 MODULAR CIRCUIT BREAKERS

MT 45 - 1P + N 2P 230V C characteristic

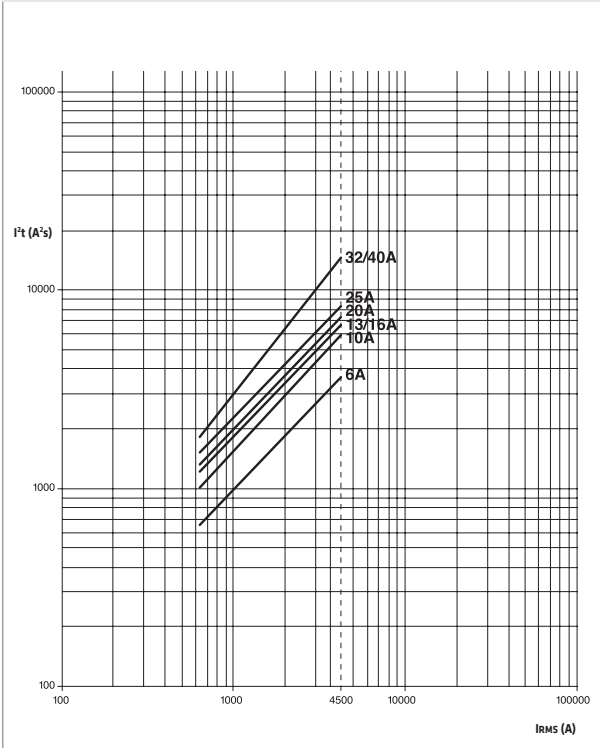

MT 45 - 2P 400V C characteristic

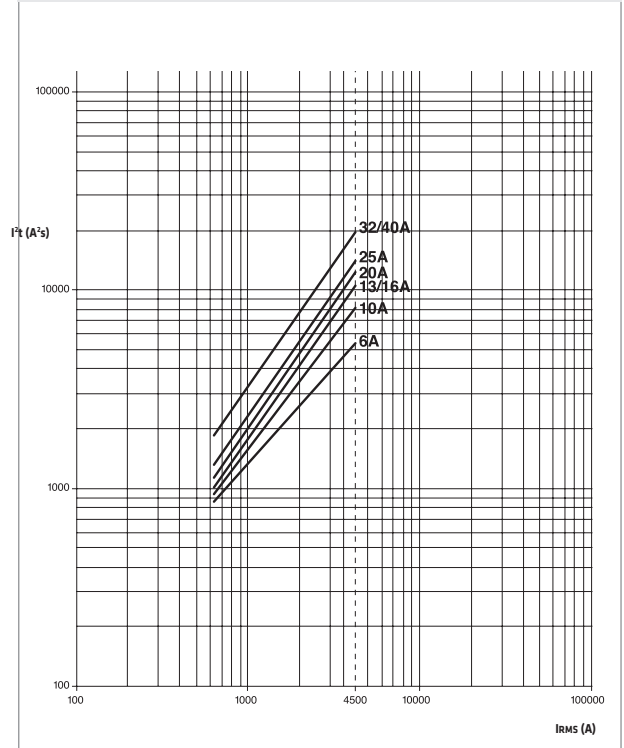

MT 45 - 1P - 230V 3P and 4P 400V C characteristic

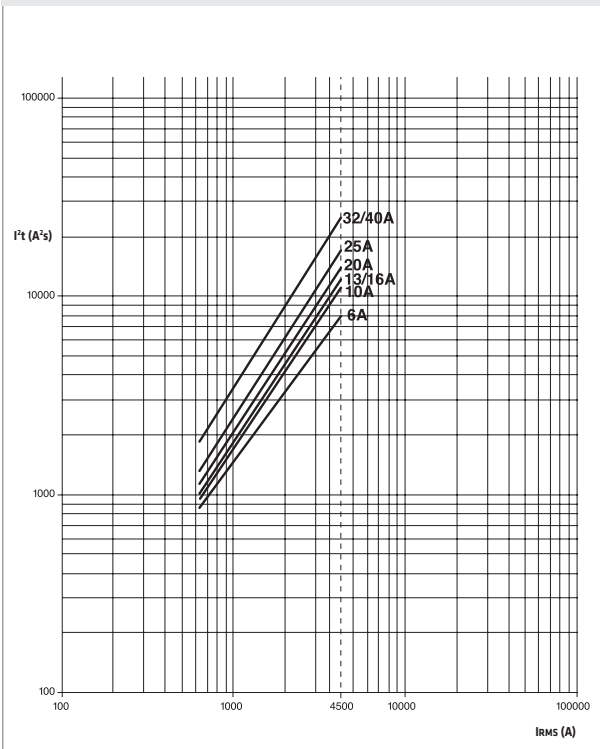

SPECIFIC LET-THROUGH ENERGY CHARACTERISTICS - MT 45 MODULAR CIRCUIT BREAKERS

MT 45 - 1P+N 2P 230V B characteristic

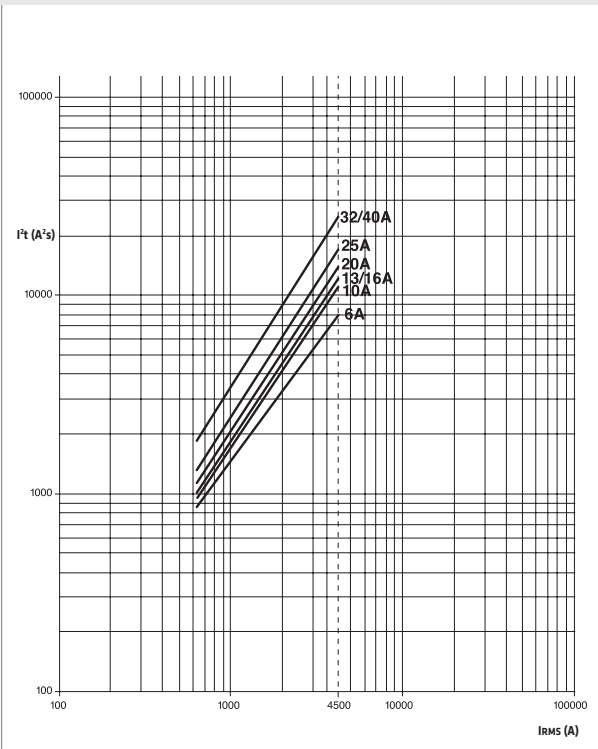

MT 45 - 2P 400V B characteristic

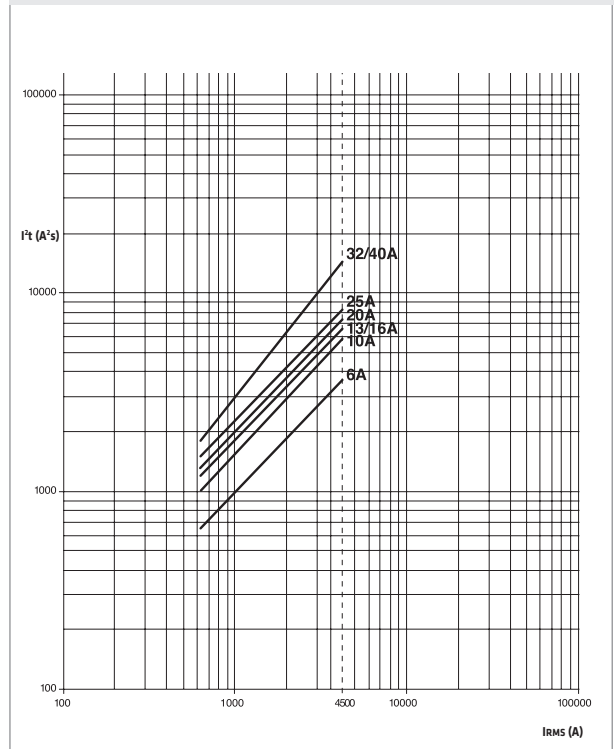

MT 45 - 1P - 230V 3P and 4P 400V B characteristic

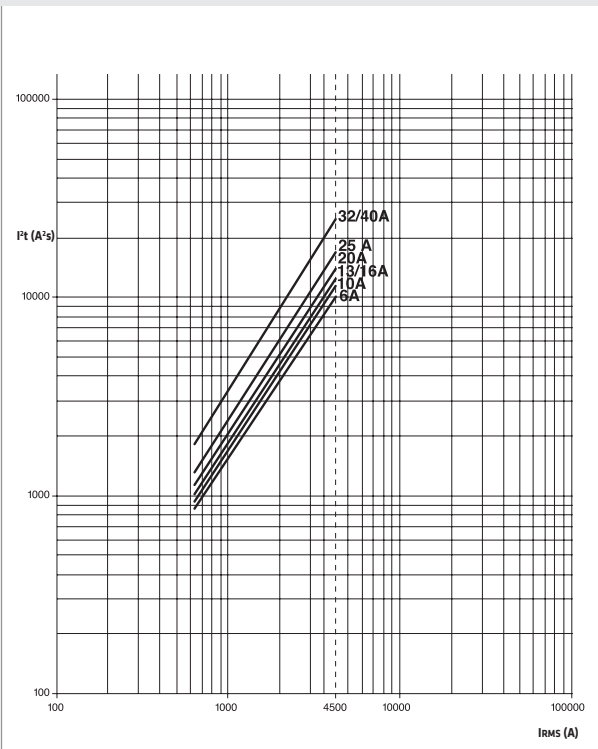

SPECIFIC LET-THROUGH ENERGY CHARACTERISTICS - MT 60 MODULAR CIRCUIT BREAKERS

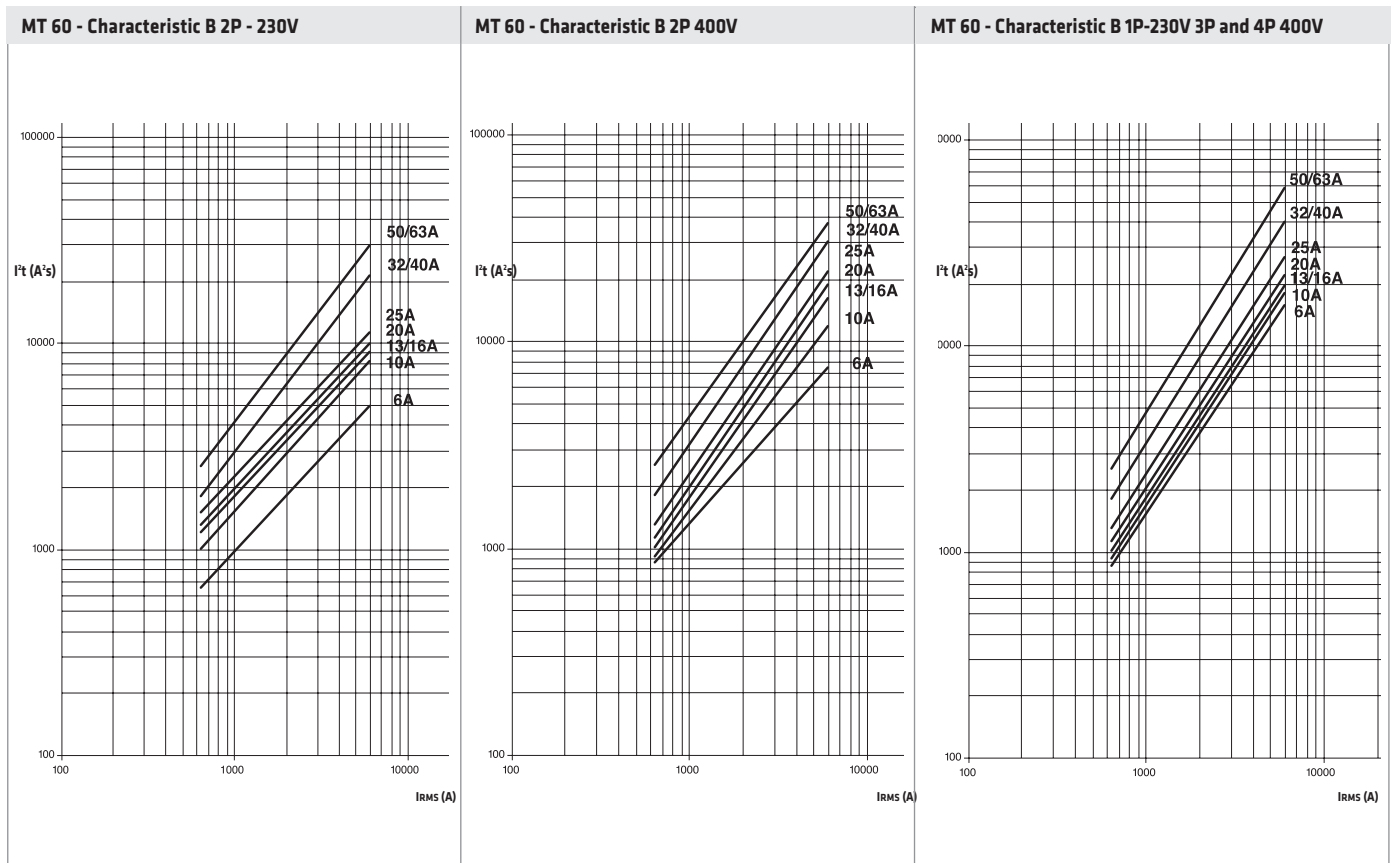
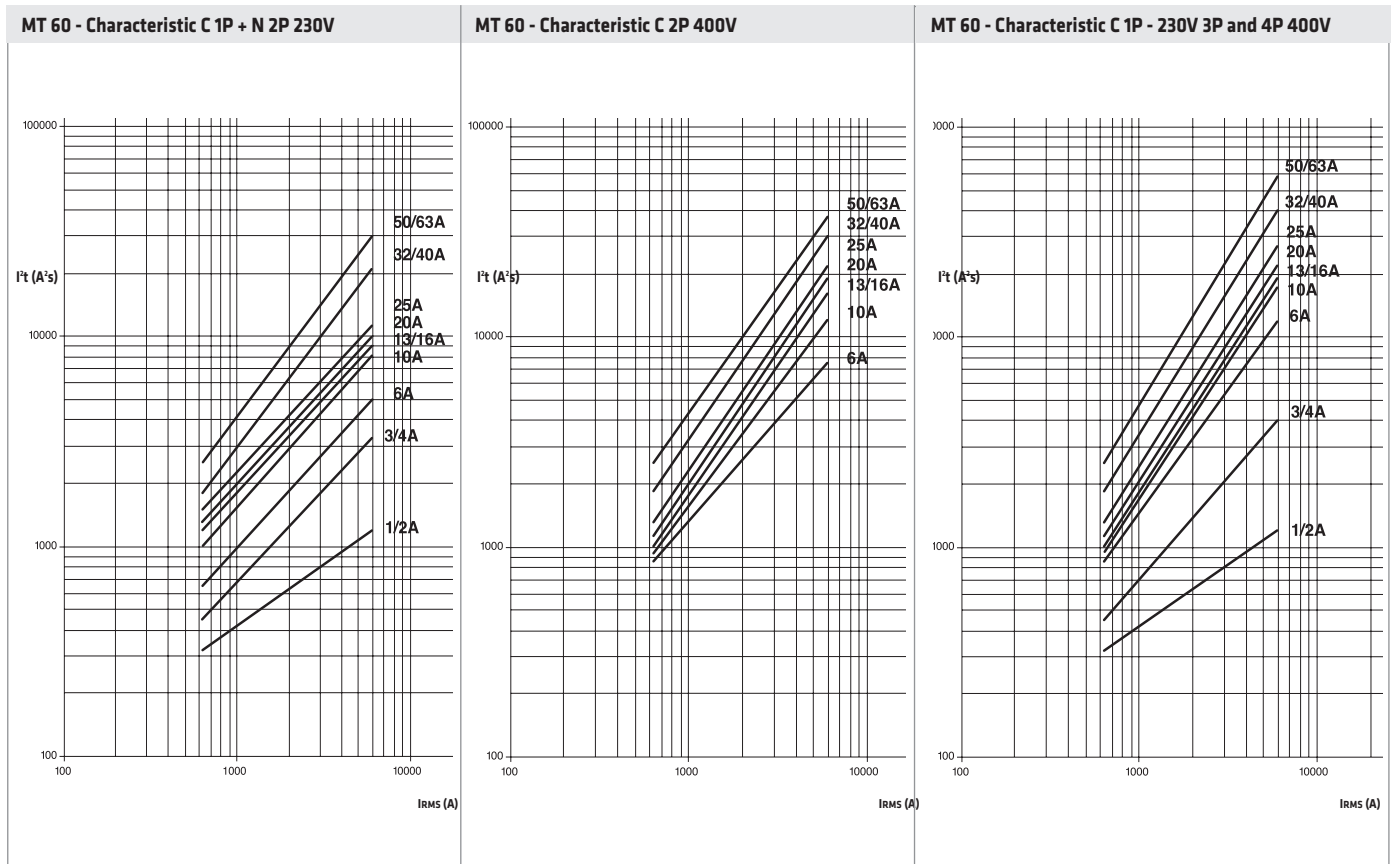

For technical information contact the Technical Assistance Service or visit gewiss.com

SPECIFIC LET-THROUGH ENERGY CHARACTERISTICS - MT 60 - MT 100 MODULAR CIRCUIT BREAKERS

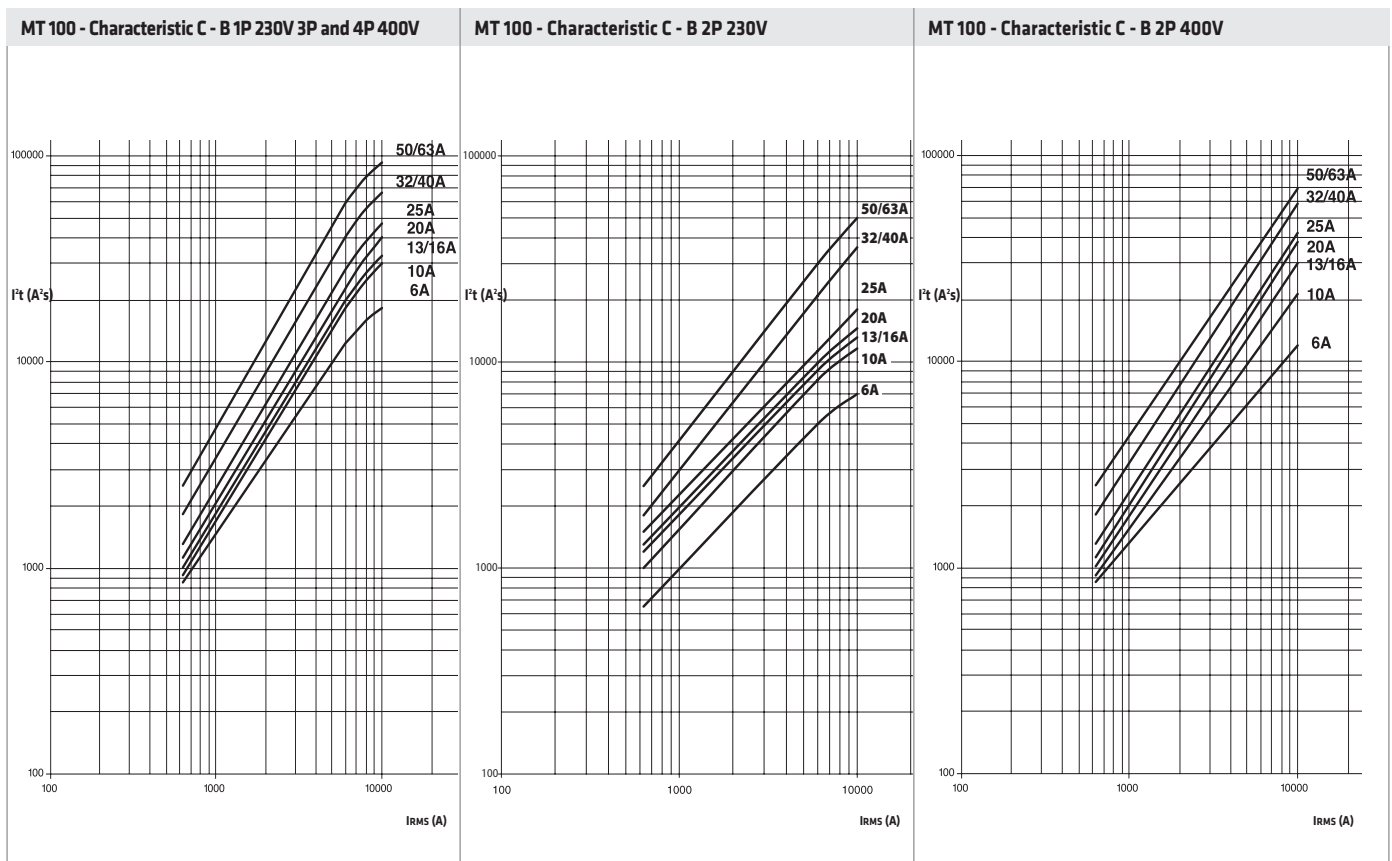
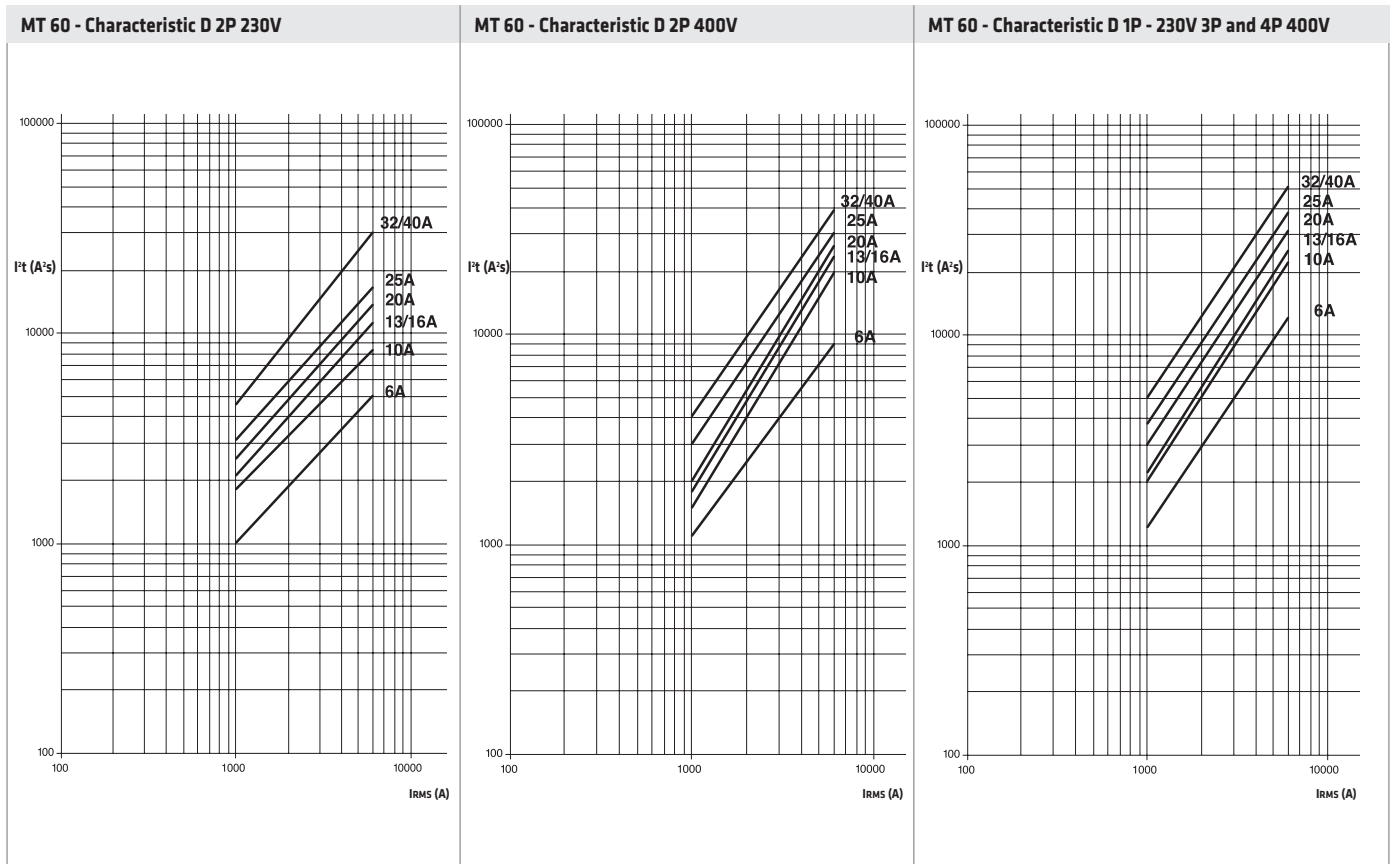

MODULAR CIRCUIT BREAKERS FOR CIRCUIT PROTECTION

SPECIFIC LET-THROUGH ENERGY CHARACTERISTICS - MT 100 - MT 250 MODULAR CIRCUIT BREAKERS

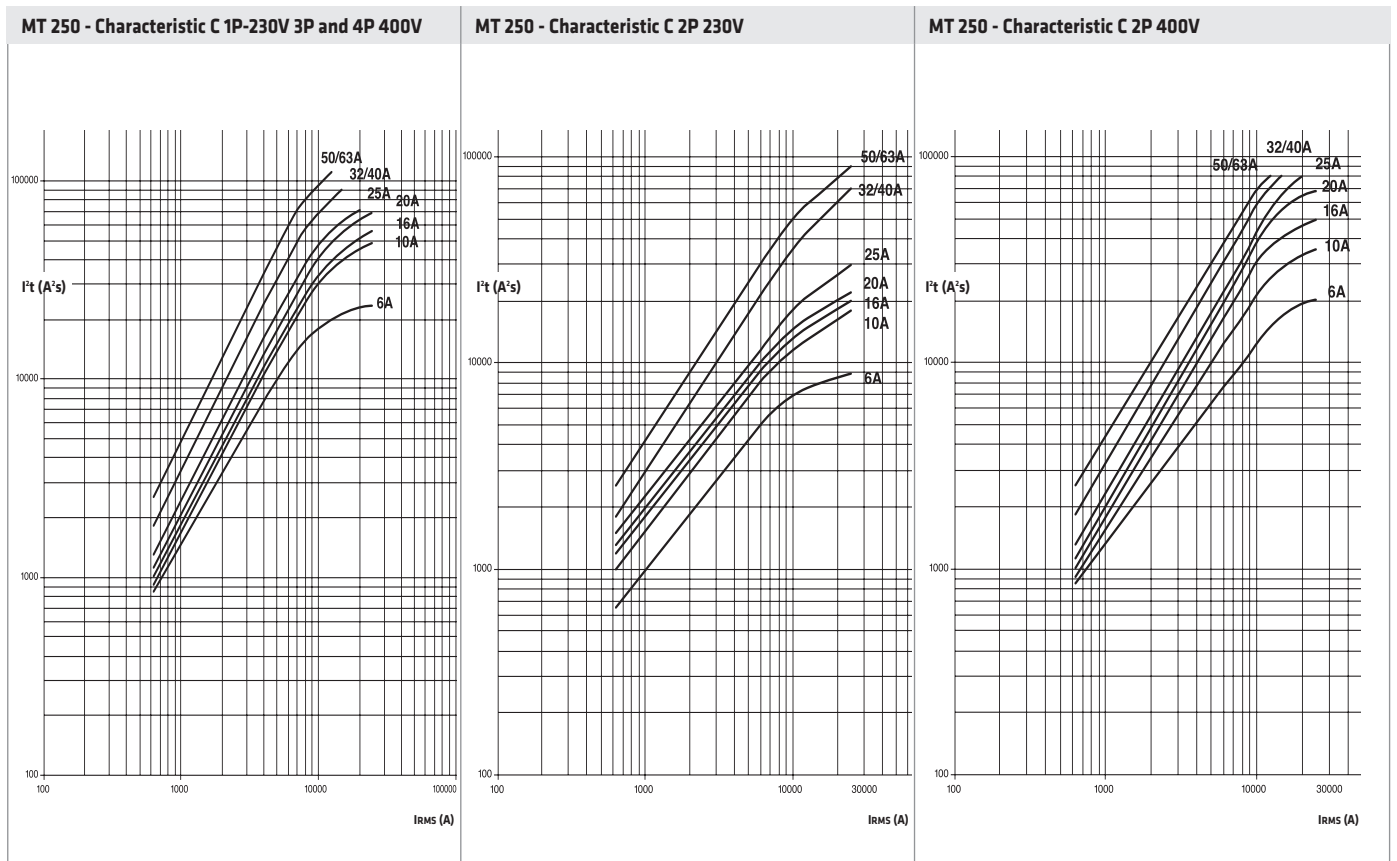
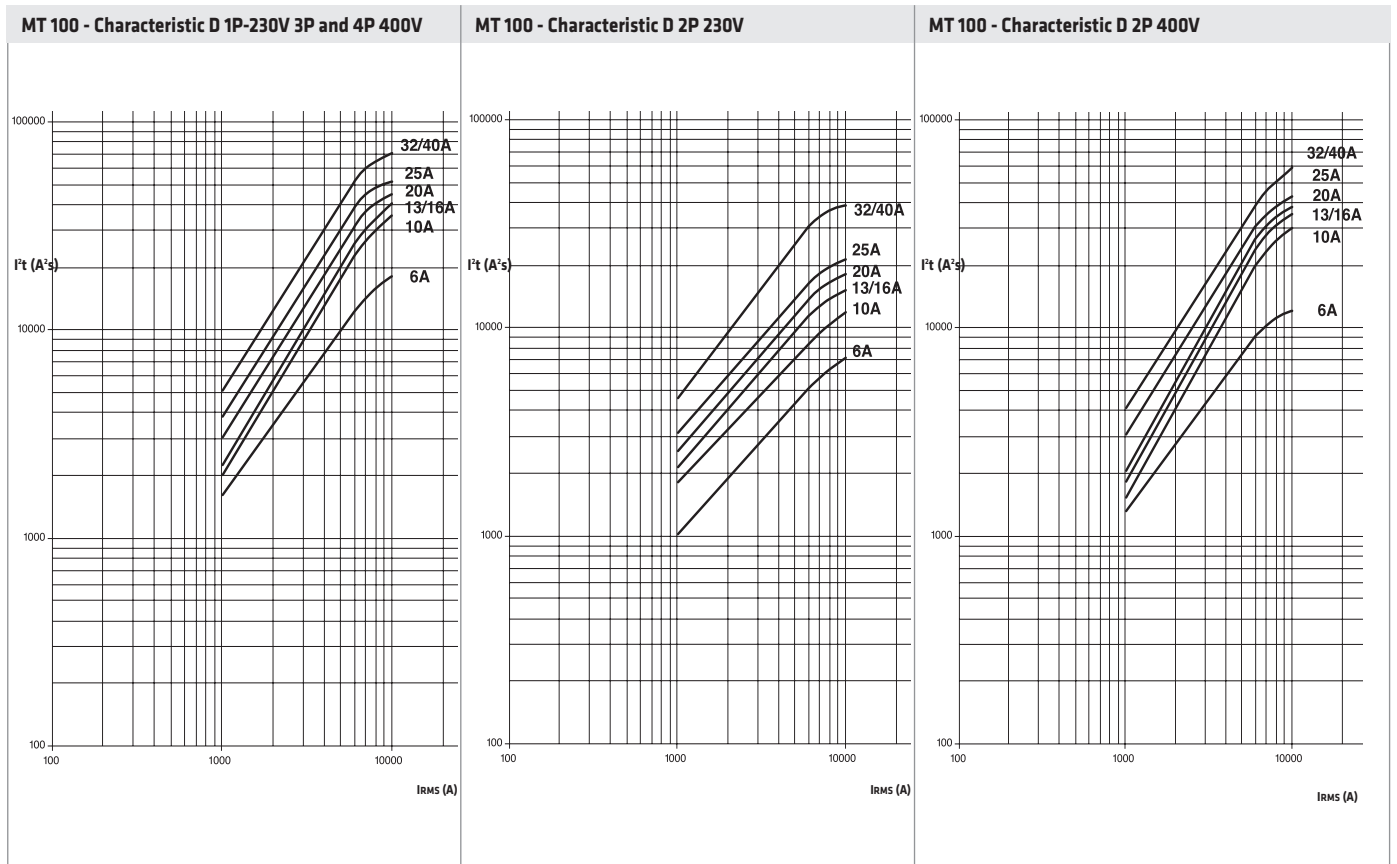

For technical information contact the Technical Assistance Service or visit gewiss.com

SPECIFIC LET-THROUGH ENERGY CHARACTERISTICS - MTHP 250 MODULAR CIRCUIT BREAKERS

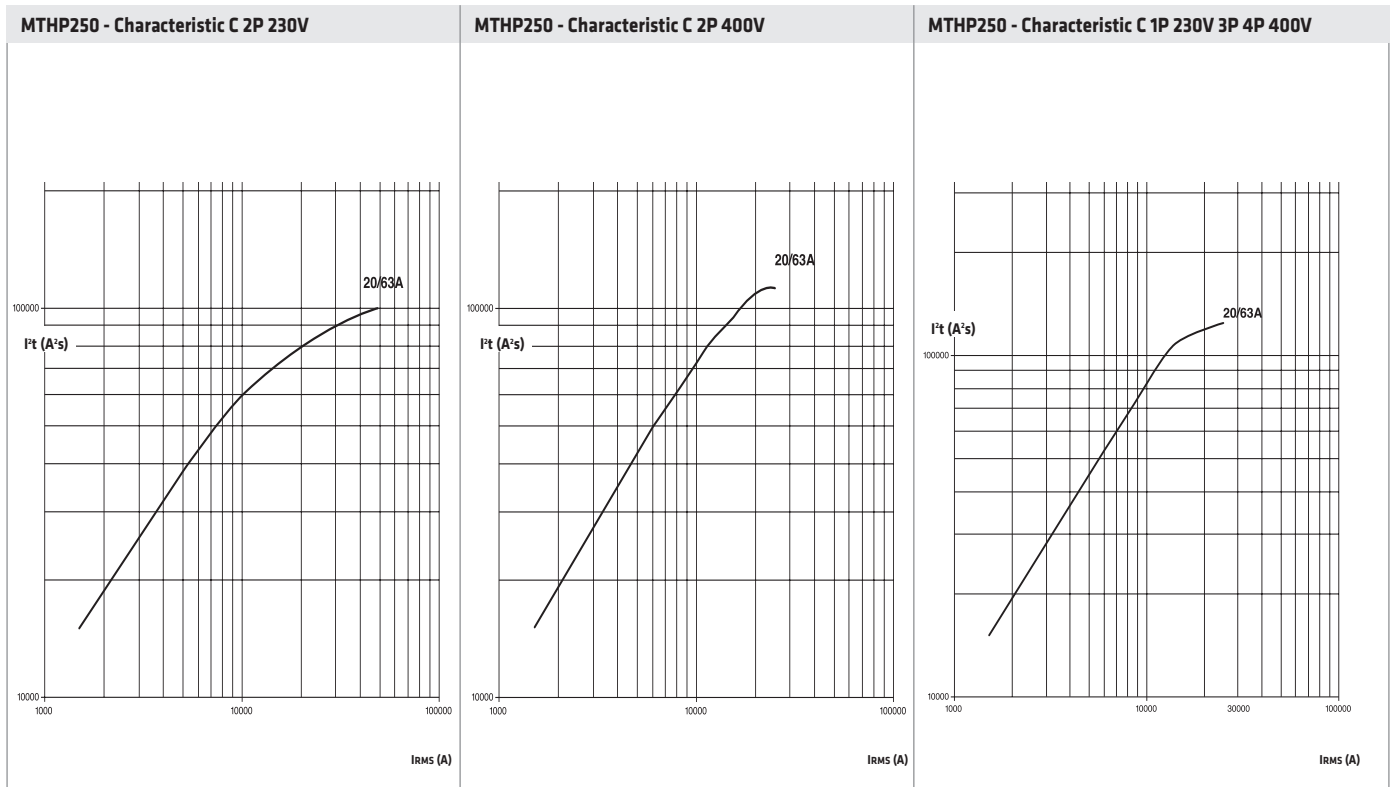

SPECIFIC LET-THROUGH ENERGY CHARACTERISTICS - MTHP 160 MODULAR CIRCUIT BREAKERS

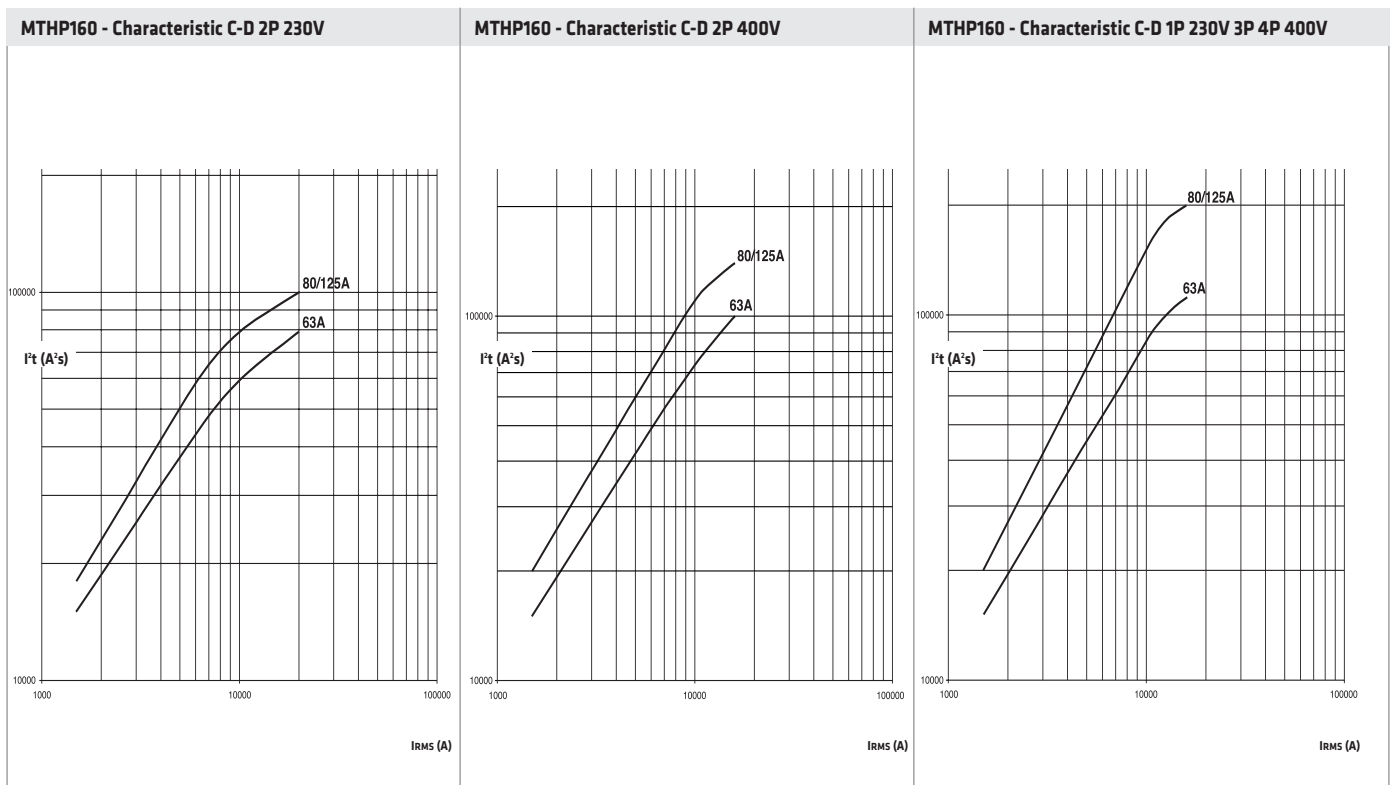

PEAK CURRENT LIMITATION CHARACTERISTICS

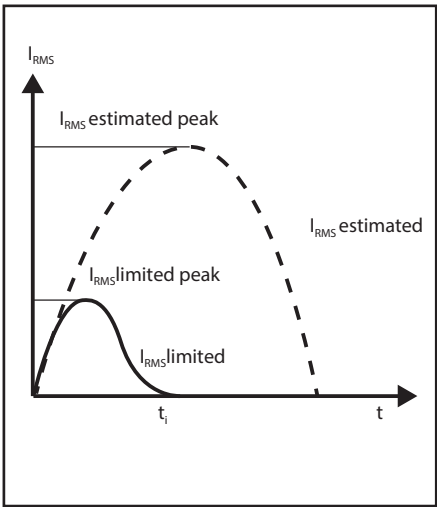
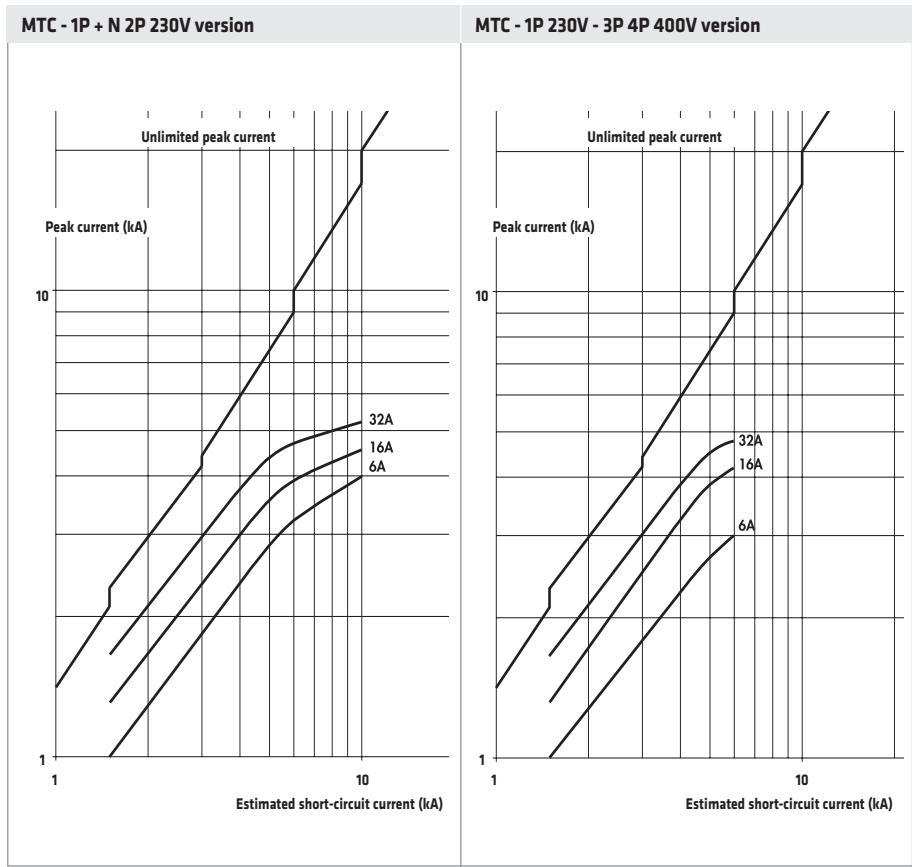

The following curves give the values of the peak current in relation to the estimated short-circuit current expressed in kA. Every curve refers to each rated current value of circuit breaker.

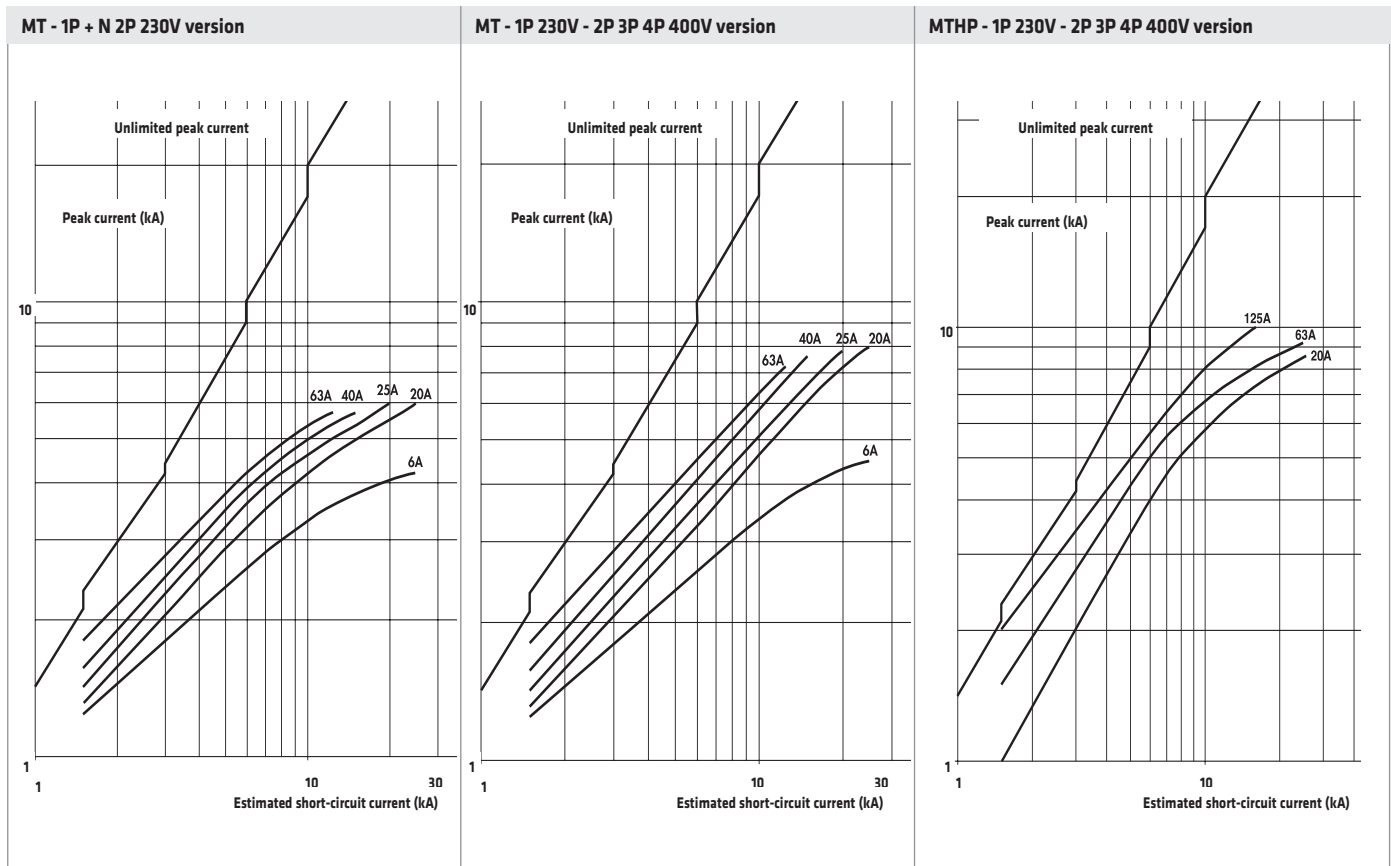

For technical information contact the Technical Assistance Service or visit gewiss.com

MODULAR CIRCUIT BREAKERS FOR CIRCUIT PROTECTION

HOW TO CHOOSE CIRCUIT BREAKERS FOR DIRECT CURRENT APPLICATIONS

The interruption of direct current is more difficult to achieve than the alternating current because the direct current doesn't go through zero at each half cycle. Therefore, it is necessary to connect in series the poles of the same circuit breaker so that the increase of the resistance, thus created, causes the decrease of the current until its cancellation.

Moreover, if the operating voltage of the system increases, also the number of poles connected in series must increase.

For a correct choice of a circuit breaker to protect DC electrical loads, it's suggested to keep in mind these following 3 factors:

- 1. Operating voltage**, which effects the number of poles to be connected in series. The maximum operating voltage in direct current for Gewiss circuit breaker is equal to 220V by connecting 4 poles in series (max 50V per pole).

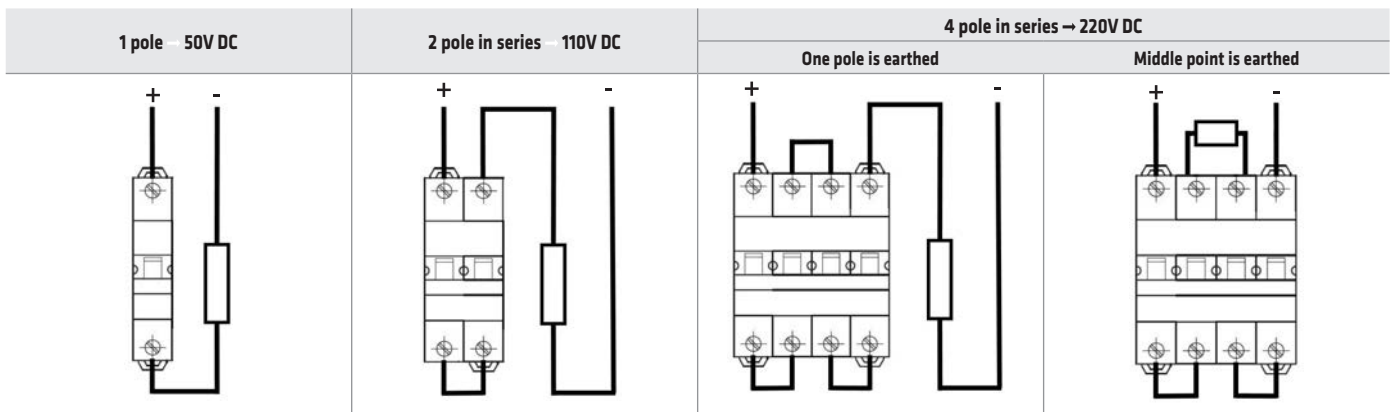

- 2. Short-circuit current**, alleged in the installation point that effects the choice of circuit breaker type.

| Circuit breaker type | BREAKING CAPACITY I_{cu} (kA) | | |
|----------------------|---------------------------------|--------|-----|
| | Operating voltage (V) | | |
| | 50 | 110 | 220 |
| MTC 45 | 6 | 6 | 4.5 |
| MTC 60 | 10 | 10 | 6 |
| MTC 100 | - | 10 (*) | - |
| MT 45 | 6 | 6 | 4.5 |
| MT 60 | 10 | 10 | 10 |
| MT 100 | 10 | 15 | 15 |
| MT 250 | 20 | 25 | 25 |
| MTHP 160 | 10 | 15 | 15 |
| MTHP 250 | 25 | 30 | 25 |

(*) 15 kA at 50V

- 3. Operating current and the type of electrical load**, which effect the rated current of the circuit breaker and its tripping characteristic.
The rated current of the circuit breaker for DC application must be higher than the operating current of electrical load and must be lower or equal to the capacity of the cable, as well as alternating current situation.
In addition to inrush current, the choice of tripping characteristics must consider that the DC magnetic trip threshold is greater than alternating current. Hereafter the tripping characteristics according to EN 60898 of circuit breakers used in direct current.

Tripping characteristics in direct current (EN 60898)

MTC 45 - 60 - 100 Characteristic C
MT 45 - MT 60 - 100 - 250 Characteristic C
MTHP 160 - 250 Characteristic C

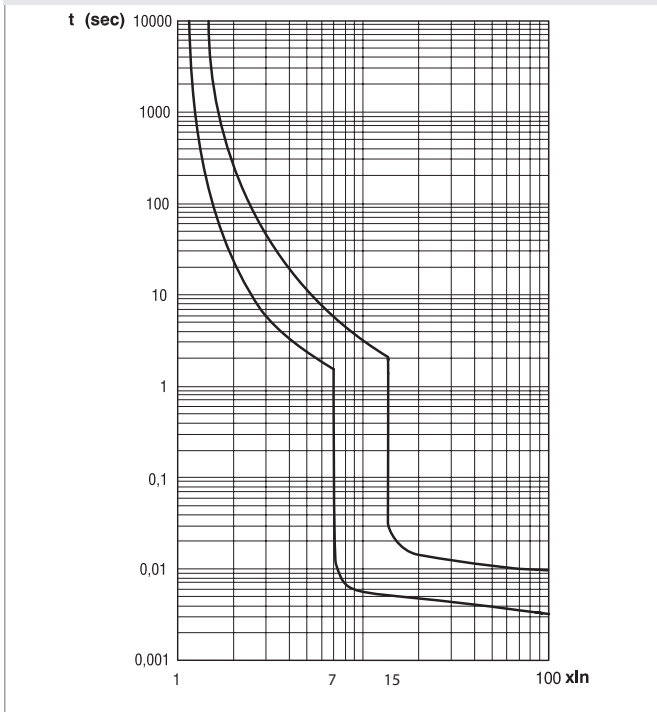

MT 45 - MT 60 - 100 Characteristic B
MTC 60 Characteristic B

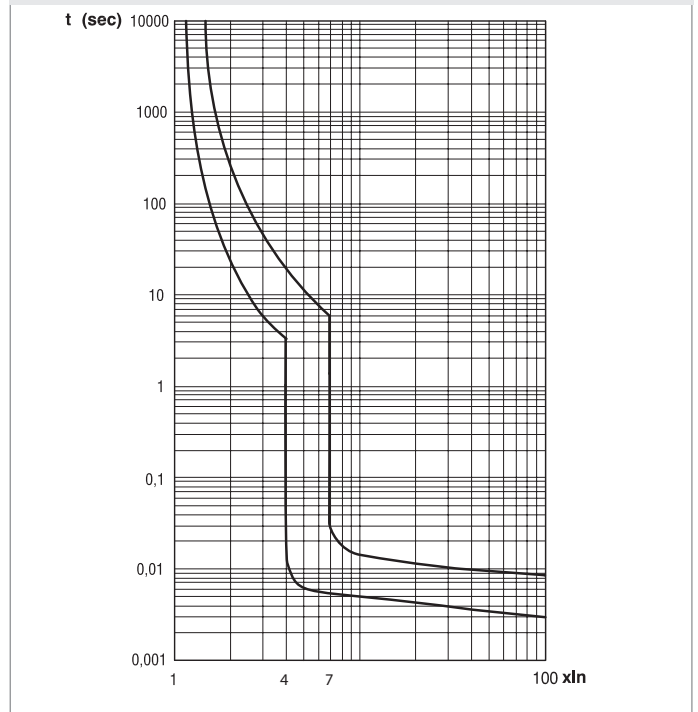

MT 60 - 100 Characteristic D
MTHP 160 Characteristic D

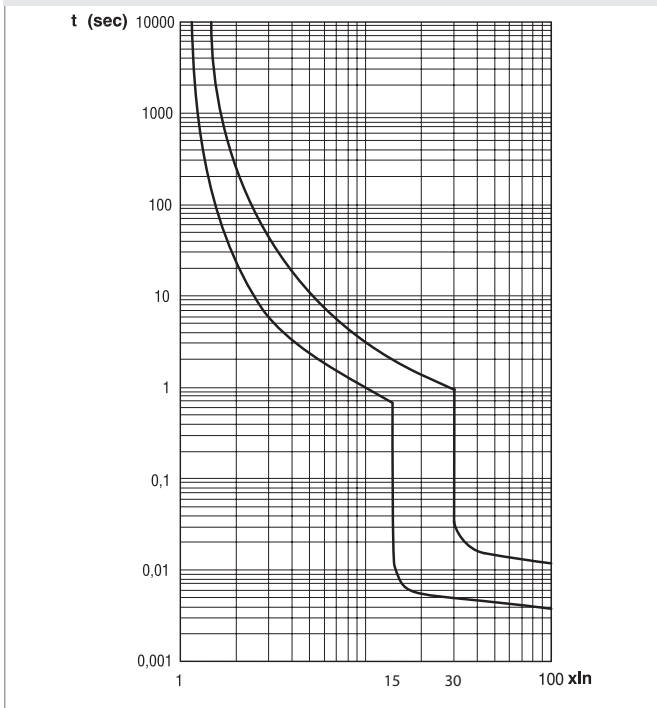

| Tripping characteristic | B | C | D |
|-------------------------|----------------|-----------------|-----------------|
| I_n | from 6 to 63 A | from 1 to 125 A | from 6 to 100 A |
| Thermal release | | | |
| I_{nf} | 1,13 I_n | 1,13 I_n | 1,13 I_n |
| I_f | 1,45 I_n | 1,45 I_n | 1,45 I_n |
| t | < 1 h | < 1 h | < 1 h |
| Magnetic release | | | |
| I_{nf} | 4 I_n | 7 I_n | 15 I_n |
| I_f | 7 I_n | 15 I_n | 30 I_n |
| t | instantaneous | instantaneous | instantaneous |

I_n = rated current
 I_{nf} = conventional non-tripping current
 I_f = conventional tripping current
 t = tripping time

B tripping curve: tripping characteristic for the protection of electrical resistive loads (for example: heating) and very long electrical distribution lines.

C tripping curve: tripping characteristic for the protection of general electrical resistive or slight inductive loads (for example: fluorescent lamps).

D tripping curve: tripping characteristic for the protection of electrical heavy inductive loads or high starting currents (for example: electrical engines).

MODULAR CIRCUIT BREAKERS FOR CIRCUIT PROTECTION

COORDINATION TABLES BACKUP

Back-up protection means to put two circuit breakers in series using their capacity to limit the short circuit in order to install a downstream circuit breaker with breaking capacity lower than required. Therefore, the upstream circuit breaker (with breaking capacity at least equal to the estimated short circuit current at the point of installation) trips to help the downstream circuit breaker to break the short circuit increasing its breaking capacity. Back-up protection is useful in every electrical installation where the continuity of working is not a fundamental requirement (as instead for selective protection) but there are other priority needs:

- to decrease the costs of electrical system because back-up allows the choice of circuit breakers with lower breaking capacity than required and therefore less expensive;

| | | BACK UP TABLES - 400V AC UPSTREAM - 230V AC DOWNSTREAM (EN 60947-2) | | | | | | | |
|------------|------------|---|----------|------|-------|-------|------|-------|-------|
| DOWNSTREAM | UPSTREAM | 400V (AC) | | | | | | | |
| | | RANGE | | MT60 | MT100 | | | MT250 | |
| 230V (AC) | Range | In [A] | Icu [kA] | 1÷63 | 1÷25 | 32÷63 | 6÷20 | 25 | 32÷63 |
| | | MTC/MDC45 | 6÷32 | 6 | 7,5 | 7,5 | 7,5 | 10 | 10 |
| | MTC/MDC60 | 6÷32 | 7,5 | 10 | 10 | 10 | 15 | 15 | 10 |
| | MTC/MDC100 | 6÷32 | 10 | | 15 | 12,5 | 17,5 | 17,5 | 12,5 |
| | MT60 | 1÷63 (1P+N) | 10 | | 15 | 12,5 | 17,5 | 17,5 | 12,5 |
| | | 1÷63 (2P) | 20 | | | | 25 | | |
| | MT100 | 1÷25 | 30 | | | | | | |
| | | 32÷63 | 25 | | | | | | |
| | MT250 | 6÷20 | 50 | | | | | | |
| | | 25 | 40 | | | | | | |
| | | 32÷40 | 30 | | | | | | |
| | MTHP160 | 63÷125 | 20 | | | | | | |
| | MTHP250 | 20÷63 | 50 | | | | | | |

| | | BACK UP TABLES - 400V AC UPSTREAM - 400V AC DOWNSTREAM (EN 60947-2) | | | | | | | | | | | | | |
|------------|--------------|---|----------|------|-------|-------|------|-------|-------|--------|---------|---------|----------|----|----|
| DOWNSTREAM | UPSTREAM | 400V (AC) | | | | | | | | | | | | | |
| | | RANGE | | MT60 | MT100 | | | MT250 | | | MTHP160 | MTHP250 | MTX 160c | | |
| 400V (AC) | Range | In [A] | Icu [kA] | 1÷63 | 1÷25 | 32÷63 | 6÷20 | 25 | 32÷63 | 63÷125 | 20÷63 | 160 | | | |
| | | | | 10 | 15 | 12,5 | 25 | 20 | 15 | 16 | 25 | 16 | 25 | 36 | |
| | MTC 45/MDC45 | 6÷32 | 4,5 | 6 | 7,5 | 6 | 10 | 10 | 7,5 | 6 | 6 | 6 | 6 | 6 | 6 |
| | MTC 60/MDC60 | 6÷32 | 6 | 10 | 12 | 10 | 15 | 15 | 12 | 10 | 10 | 10 | 10 | 10 | 10 |
| | MT 60 | 1÷63 | 10 | | 15 | 12 | 18 | 18 | 15 | 16 | 20 | 16 | 20 | 20 | |
| | MT 100 | 1÷25 | 15 | | | | 25 | 20 | | 16 | 25 | 16 | 25 | 25 | |
| | | 32÷63 | 12,5 | | | | 25 | 20 | 15 | 16 | 20 | 16 | 25 | 25 | |
| | MT 250 | 6÷20 | 25 | | | | | | | | | | | 36 | |
| | | 25 | 20 | | | | | | | | 25 | | 25 | 25 | |
| | MTX 160c | 32÷63 | 15 | | | | | | | 16 | 20 | 16 | 25 | 25 | |
| | | 63÷125 | 16 | | | | | | | | | | | | |
| | MTHP 160 | 20÷63 | 25 | | | | | | | | | | | | |
| | MTHP 250 | | | | | | | | | | | | | | |
| MTX/E 160 | 160 | 16 | | | | | | | | | | | 25 | 36 | |
| | | 25 | | | | | | | | | | | 36 | | |
| | | 36 | | | | | | | | | | | | | |
| MTX 250 | 250 | 36 | | | | | | | | | | | | | |
| | | 50 | | | | | | | | | | | | | |
| MTX/E 320 | 320 | 36 | | | | | | | | | | | | | |
| | | 50 | | | | | | | | | | | | | |
| | | 70 | | | | | | | | | | | | | |
| | | 120 | | | | | | | | | | | | | |
| MTX/E 630 | 630 | 36 | | | | | | | | | | | | | |
| | | 50 | | | | | | | | | | | | | |
| | | 70 | | | | | | | | | | | | | |
| MTX/E 1000 | 1000 | 120 | | | | | | | | | | | | | |
| | | 36 | | | | | | | | | | | | | |
| | | 50 | | | | | | | | | | | | | |
| | | 70 | | | | | | | | | | | | | |
| MTX/E 1000 | 1000 | 100 | | | | | | | | | | | | | |
| | | 36 | | | | | | | | | | | | | |
| | | 50 | | | | | | | | | | | | | |

Note: kA values

For technical information contact the Technical Assistance Service or visit gewiss.com

MODULAR CIRCUIT BREAKERS FOR CIRCUIT PROTECTION

- to limit the size of circuit breakers;
- to maintain existing electrical systems even if they are not still suitable to break the new value of short-circuit.

The following tables cover the possible combinations between Gewiss circuit breakers range for electrical networks 230 and 400V in order the specific let-through energy of upstream circuit breaker is not so high to damage the downstream circuit breaker. The numbers give the value of the breaking capacity expressed in kA considering the combination of the two switches selected.

BACK UP TABLES - 400V AC UPSTREAM - 230V AC DOWNSTREAM (EN 60947-2)

| 400V (AC) | | | | | | | | | | | |
|-----------|--|---------|--|----------|------|----|-----------|----|----|---------|----|
| MTHP160 | | MTHP250 | | MTX 160c | | | MTX/E 160 | | | MTX 250 | |
| 63÷125 | | 20÷63 | | 160 | | | 160 | | | 250 | |
| 16 | | 25 | | 16 | 25 | 36 | 36 | 50 | 70 | 36 | 50 |
| 7,5 | | 10 | | 7,5 | 10 | 10 | | | | | |
| 10 | | 17,5 | | 10 | 12,5 | 16 | 10 | 16 | 16 | 10 | 16 |
| 12,5 | | 20 | | 16 | 16 | 16 | 16 | 16 | 16 | 16 | 16 |
| 12,5 | | 20 | | 16 | 16 | 16 | 16 | 16 | 16 | 16 | 16 |
| | | 25 | | | 25 | 30 | 25 | 30 | 30 | 25 | 30 |
| | | | | | | 36 | 36 | 40 | 50 | 36 | 40 |
| | | | | | | 36 | 36 | 40 | 50 | 36 | 40 |
| | | | | | | | | 50 | 50 | | 50 |
| | | | | | | 36 | 36 | 50 | 50 | 36 | 50 |
| | | | | | | 36 | 36 | 36 | 50 | 36 | 36 |
| | | | | | | | 25 | 36 | 36 | 25 | 36 |

BACK UP TABLES - 400V AC UPSTREAM - 400V AC DOWNSTREAM (EN 60947-2)

| 400V (AC) | | | | | | | | | | | | | | | | | | | | |
|-----------|----|----|---------|----|-----------|----|----|-----|----|-----------|----|-----|----|------------|----|-----|-----|-----------|-----|----|
| MTX/E 160 | | | MTX 250 | | MTX/E 320 | | | | | MTX/E 630 | | | | MTX/E 1000 | | | | MTSE 1600 | | |
| 160 | | | 250 | | 320 | | | | | 630 | | | | 1000 | | | | 1600 | | |
| 36 | 50 | 70 | 36 | 50 | 36 | 50 | 70 | 120 | 36 | 50 | 70 | 120 | 36 | 50 | 70 | 100 | 50 | 65 | 100 | |
| 10 | 10 | 10 | | | 10 | 10 | 10 | 10 | | | | | | | | | | | | |
| 20 | 20 | 20 | 16 | 16 | 20 | 20 | 20 | 20 | | | | | | | | | | | | |
| 25 | 30 | 30 | 25 | 30 | 25 | 25 | 25 | 30 | | | | | | | | | | | | |
| 25 | 25 | 25 | 20 | 25 | 25 | 25 | 25 | 30 | | | | | | | | | | | | |
| 30 | 36 | 36 | 30 | 30 | 30 | 30 | 30 | 30 | | | | | | | | | | | | |
| 30 | 36 | 36 | 25 | 25 | 25 | 30 | 30 | 30 | | | | | | | | | | | | |
| 25 | 25 | 30 | 20 | 20 | 20 | 25 | 25 | 25 | | | | | | | | | | | | |
| 25 | 25 | 30 | 20 | 20 | 20 | 25 | 25 | 25 | | | | | | | | | | | | |
| 30 | 30 | 36 | 30 | 30 | 30 | 30 | 30 | 30 | | | | | | | | | | | | |
| 36 | 50 | 70 | 36 | 50 | 30 | 36 | 40 | 50 | 30 | 36 | 40 | 50 | 30 | 36 | 40 | 50 | | | | |
| 36 | 50 | 70 | 36 | 50 | 36 | 40 | 65 | 85 | 36 | 40 | 65 | 85 | 36 | 50 | 65 | 70 | 50 | 50 | 50 | |
| | 50 | 70 | | 50 | | 50 | 65 | 100 | | 50 | 65 | 100 | | 50 | 65 | 70 | 50 | 50 | 50 | |
| | 50 | 70 | | 50 | | 50 | 65 | 100 | | 50 | 65 | 100 | | 50 | 65 | 85 | 50 | 65 | 85 | |
| | | | | | | | 70 | 100 | | | 70 | 100 | | | 70 | 85 | | 65 | 85 | |
| | | | | | | | | 120 | | | | 120 | | | | 85 | | | 85 | |
| | | | | 50 | | 50 | 65 | 100 | | 50 | 65 | 100 | | 50 | 65 | 100 | 50 | 50 | 50 | |
| | | | | | | | 70 | 100 | | | 70 | 100 | | | 70 | 100 | | 65 | | |
| | | | | | | 50 | 65 | 100 | | 50 | 65 | 100 | | 50 | 65 | 65 | 50 | 50 | 65 | |
| | | | | | | | 70 | 100 | | | 70 | 100 | | | 70 | 85 | | 65 | 85 | |
| | | | | | | | | 120 | | | | 120 | | | | 100 | | | 100 | |
| | | | | | | | | | | 50 | 65 | 100 | | 50 | 65 | 85 | 50 | 50 | 65 | |
| | | | | | | | | | | | 70 | 100 | | | 70 | 85 | | 65 | 85 | |
| | | | | | | | | | | | | 120 | | | | 100 | | | 100 | |
| | | | | | | | | | | | | | | | | | | | | |
| | | | | | | | | | | | | | | | 50 | 65 | 70 | 40 | 40 | 50 |
| | | | | | | | | | | | | | | | | 70 | 85 | | | 85 |
| | | | | | | | | | | | | | | | | | 100 | | | |

For technical information contact the Technical Assistance Service or visit gewiss.com

MODULAR CIRCUIT BREAKERS FOR CIRCUIT PROTECTION

SELECTIVITY TABLES

The following tables show the energy selectivity type combination between each circuit breaker belonging to the Gewiss range. The energy selectivity type, as other types, has the aim to ensure maximum continuity of working, even in the case of fault, suppling only the electrical circuits without fault and tripping the circuit breakers of fault circuits. This coordination requires the upstream circuit breaker is dimensioned enough to let pass the fault current for a time as long as necessary the downstream circuit breaker trips. The energy selectivity can be of two types:

| SELECTIVITY TABLE - 400 Vac UPSTREAM - 400 Vac DOWNSTREAM (EN 60947-2) | | | | | | | | | | | | | | | | | | | | | | | | | |
|--|-------|----------|-----|-----|-----|-----|-----|------|------|-----|-----|----------|------|------|----|---------|-----|-----|----|------|-----|------|------|------|-----|
| UPSTREAM | | MTX 160c | | | | | | | | | | MTXE 160 | | | | MTX 250 | | | | | | | | | |
| DOWNSTREAM | | TM1 | | | | | | | | | | SEP/1 | | | | TM1 | | | | | | | | | |
| Range | Curve | In | 16 | 20 | 25 | 32 | 40 | 50 | 63 | 80 | 100 | 125 | 160 | 10 | 25 | 63 | 100 | 160 | 63 | 80 | 100 | 125 | 160 | | |
| MTC 45 MDC 45 | C | 6 | T | T | T | T | T | T | T | T | T | T | T | | | T | T | T | T | T | T | T | T | T | |
| | | 10 | | 3 | 3 | 3 | 3 | 3 | 3 | 5 | 5 | 5 | 5 | | | T | T | T | T | T | T | T | T | T | T |
| | | 16 | | | | | 3 | 3 | 3 | 4,5 | 4,5 | 4,5 | 4,5 | | | | T | T | T | T | T | T | T | T | T |
| | | 20 | | | | | 3 | 3 | 3 | 3,5 | 3,5 | 3,5 | 3,5 | | | | T | T | T | T | 5,5 | 5,5 | 5,5 | 5,5 | 5,5 |
| | | 25 | | | | | | | 3 | 3,5 | 3,5 | 3,5 | 3,5 | | | | T | T | T | T | 5,5 | 5,5 | 5,5 | 5,5 | 5,5 |
| | | 32 | | | | | | | 3 | | 4,5 | 4,5 | 4,5 | | | | T | T | T | | 4,5 | 4,5 | 4,5 | 4,5 | 4,5 |
| MTC 60/100 MDC 60/100 | B/C | 6 | 5,5 | 5,5 | 5,5 | 5,5 | 5,5 | 5,5 | T | T | T | T | T | | | T | T | T | T | T | T | T | T | T | |
| | | 10 | | | 3 | 3 | 3 | 3 | 4,5 | 5 | 8,5 | 8,5 | 8,5 | | | T | T | T | T | 7,5 | 8,5 | 8,5 | 8,5 | 8,5 | |
| | | 16 | | | | 3 | 3 | 3 | 4,5 | 4,5 | 7,5 | 7,5 | 7,5 | | | | T | T | T | 5 | 7,5 | 7,5 | 7,5 | 7,5 | |
| | | 20 | | | | 3 | 3 | 3 | 3,5 | 3,5 | 5,5 | 5,5 | 5,5 | | | | T | T | T | 5 | 5,5 | 5,5 | 5,5 | 5,5 | |
| | | 25 | | | | | | 3 | 3,5 | 3,5 | 5,5 | 5,5 | 5,5 | | | | T | T | T | 5 | 5,5 | 5,5 | 5,5 | 5,5 | |
| | | 32 | | | | | | 3 | | 4,5 | 4,5 | 5,5 | 5,5 | | | | T | T | T | | 4,5 | 7 | 7 | 7 | |
| MT 60 | B/C | 1 | T | T | T | T | T | T | T | T | T | T | T | T | T | T | T | T | T | T | T | T | T | T | |
| | | 2 | T | T | T | T | T | T | T | T | T | T | T | T | T | T | T | T | T | T | T | T | T | T | |
| | | 3 | T | T | T | T | T | T | T | T | T | T | T | T | T | T | T | T | T | T | T | T | T | T | |
| | | 4 | T | T | T | T | T | T | T | T | T | T | T | T | T | T | T | T | T | T | T | T | T | T | |
| | | 6 | 5,5 | 5,5 | 5,5 | 5,5 | 5,5 | 5,5 | 5,5 | T | T | T | T | T | | | T | T | T | T | T | T | T | T | |
| | | 10 | | | 3 | 3 | 3 | 3 | 4,5 | 5,5 | 8,5 | 8,5 | 8,5 | | | T | T | T | T | 7,5 | 8,5 | 8,5 | 8,5 | 8,5 | |
| | | 16 | | | | | 3 | 3 | 4,5 | 4,5 | 7,5 | 7,5 | 7,5 | | | | T | T | T | 5 | 7,5 | 7,5 | 7,5 | 7,5 | |
| | | 20 | | | | | | 3 | 3,5 | 3,5 | 5,5 | 5,5 | 5,5 | | | | T | T | T | 5 | 5,5 | 5,5 | 5,5 | 5,5 | |
| | | 25 | | | | | | | | 3,5 | 3,5 | 5,5 | 5,5 | | | | T | T | T | 5 | 5,5 | 5,5 | 5,5 | 5,5 | |
| | | 32 | | | | | | | | | 4,5 | 4,5 | 7 | 7 | | | | T | T | | 4,5 | 7 | 7 | 7 | |
| | | 40 | | | | | | | | | | 7 | 7 | 7 | | | | T | T | | | 7 | 7 | 7 | |
| 50 | | | | | | | | | | | 6 | 6 | | | | T | T | | | | 6 | 6 | | | |
| 63 | | | | | | | | | | | | T | | | | T | T | | | | | T | | | |
| MT 60 | D | 6 | 5,5 | 5,5 | 5,5 | 5,5 | 5,5 | 5,5 | T | T | T | T | T | | | T | T | T | T | T | T | T | T | | |
| | | 10 | | | 3 | 3 | 3 | 3 | 5 | 7 | 8 | 8 | 8 | | | T | T | T | T | 5 | 8,5 | 8,5 | 8,5 | | |
| | | 16 | | | | | 2 | 2 | 3 | 5 | 8 | 8 | 8 | | | | T | T | T | 3 | 5 | 8 | 8 | | |
| | | 20 | | | | | | 2 | 3 | 4,5 | 6,5 | 8 | 8 | | | | T | T | T | 3 | 4,5 | 6,5 | 8 | | |
| | | 25 | | | | | | | | 2,5 | 4 | 6 | 8 | | | | T | T | T | 2,5 | 4 | 6 | 9,5 | | |
| | | 32 | | | | | | | | | 4 | 6 | 8 | | | | T | T | T | | 4 | 6 | 9,5 | | |
| MT 100 | B/C | 6 | 5,5 | 5,5 | 5,5 | 5,5 | 5,5 | 5,5 | 10,5 | T | T | T | T | | | T | T | T | T | 10,5 | T | T | T | | |
| | | 10 | | | 3 | 3 | 3 | 3 | 5,5 | 8,5 | 8,5 | 8,5 | 8,5 | | | T | T | T | T | 7,5 | 8,5 | 8,5 | 8,5 | | |
| | | 16 | | | | | 3 | 3 | 4,5 | 7,5 | 12 | 12 | 12 | | | | T | T | T | 5 | 7,5 | 12 | 12 | | |
| | | 20 | | | | | | 2,5 | 3,5 | 5,5 | 7,5 | 7,5 | 7,5 | | | | T | T | T | 5 | 5,5 | 8 | 8 | | |
| | | 25 | | | | | | | | 3,5 | 5,5 | 7,5 | 7,5 | | | | T | T | T | 5 | 5,5 | 8 | 8 | | |
| | | 32 | | | | | | | | | 4,5 | 7 | 12 | 12 | | | | T | T | | 4,5 | 7 | 12 | | |
| | | 40 | | | | | | | | | | 7 | 12 | 12 | | | | T | T | | | 7 | 12 | | |
| | | 50 | | | | | | | | | | | 6 | 10,5 | | | | T | T | | | | 6 | 10,5 | |
| 63 | | | | | | | | | | | | 10,5 | | | | T | T | | | | | 10,5 | | | |
| MT 100 | D | 6 | 5,5 | 5,5 | 5,5 | 5,5 | 5,5 | 10,5 | T | T | T | T | T | | | T | T | T | T | 10,5 | T | T | T | | |
| | | 10 | | | 3 | 3 | 3 | 3 | 5 | 8,5 | 8,5 | 8,5 | 8,5 | | | T | T | T | T | 5 | 8,5 | 8,5 | 8,5 | | |
| | | 16 | | | | | 2 | 2 | 3 | 5 | 8 | 13,5 | 13,5 | | | | T | T | T | 3 | 5 | 8 | 13,5 | | |
| | | 20 | | | | | | 2 | 3 | 4,5 | 6,5 | 11 | 11 | | | | T | T | T | 3 | 4,5 | 6,5 | 11 | | |
| | | 25 | | | | | | | | 2,5 | 4 | 6 | 9,5 | | | | T | T | T | 2,5 | 4 | 6 | 9,5 | | |
| | | 32 | | | | | | | | | 4 | 6 | 9,5 | | | | T | T | T | | 4 | 6 | 9,5 | | |

Note: T= total selectivity - kA values

For technical information contact the Technical Assistance Service or visit gewiss.com

SELECTIVITY TABLES

| SELECTIVITY TABLE - 400 V _{ac} UPSTREAM - 400 V _{ac} DOWNSTREAM (EN 60947-2) | | | | | | | | | | | | | | | | | | | | | | | | | | |
|--|-------|----------|-----|-----|-----|-----|-----|-----|------|-----|-----|-----|-----|----------|------|-----|-----|-----|---------|------|-----|-----|-----|-----|----|------|
| UPSTREAM | | MTX 160c | | | | | | | | | | | | MTXE 160 | | | | | MTX 250 | | | | | | | |
| DOWNSTREAM | | TM1 | | | | | | | | | | | | SEP/1 | | | | | TM1 | | | | | | | |
| Range | Curve | In | 16 | 20 | 25 | 32 | 40 | 50 | 63 | 80 | 100 | 125 | 160 | 10 | 25 | 63 | 100 | 160 | 63 | 80 | 100 | 125 | 160 | | | |
| MTX 250 | C | 6 | 5,5 | 5,5 | 5,5 | 5,5 | 5,5 | 5,5 | 10,5 | T | T | T | T | | T | T | T | T | 10,5 | T | T | T | T | | | |
| | | 10 | | 3 | 3 | 3 | 3 | 3 | 5,5 | 8,5 | T | T | T | | T | T | T | T | 7,5 | 8,5 | T | T | T | | | |
| | | 16 | | | | | | 3 | 3 | 4,5 | 7,5 | 12 | T | T | | | T | T | T | 5 | 7,5 | 12 | T | T | | |
| | | 20 | | | | | | | 2,5 | 3,5 | 5,5 | 7,5 | T | T | | | T | T | T | 5 | 5,5 | 8 | T | T | | |
| | | 25 | | | | | | | | | 3,5 | 5,5 | 7,5 | T | T | | | T | T | T | 5 | 5,5 | 8 | T | T | |
| | | 32 | | | | | | | | | | 4,5 | 7 | 12 | T | | | T | T | T | | 4,5 | 7 | 12 | T | |
| | | 40 | | | | | | | | | | | 7 | 12 | T | | | | T | T | | | 7 | 12 | T | |
| | | 50 | | | | | | | | | | | | 6 | 10,5 | | | | 10,5 | 10,5 | | | | | 6 | 10,5 |
| | | 63 | | | | | | | | | | | | | | | | | | 10,5 | | | | | | 10,5 |
| MTHP 160 | C | 80 | | | | | | | | | | | | 6 | | | | | 6 | | | | | | | |
| | | 100 | | | | | | | | | | | | | | | | | | | | | | | | |
| | | 125 | | | | | | | | | | | | | | | | | | | | | | | | |
| MTHP 160 | D | 80 | | | | | | | | | | 6 | 7,5 | | | | | 7,5 | | | | | | 9,5 | | |
| | | 100 | | | | | | | | | | | 6 | | | | | 6 | | | | | | | | |
| | | 125 | | | | | | | | | | | | | | | | | | | | | | | | |
| MTHP 250 | C | 20 | | | | | 5,5 | 5,5 | T | T | T | T | T | | | T | T | T | 2,5 | 5,5 | 8 | T | T | | | |
| | | 25 | | | | | | | 3,5 | 5,5 | 7,5 | T | T | | | 3,5 | 7,5 | T | | 5 | 8 | T | T | | | |
| | | 32 | | | | | | | | 4,5 | 7 | T | T | | | | 7 | T | | 4,5 | 7 | T | T | | | |
| | | 40 | | | | | | | | | 7 | T | T | | | | 7 | T | | | 7 | T | T | | | |
| | | 50 | | | | | | | | | | 6 | T | | | | | | T | | | | 6 | T | | |
| | | 63 | | | | | | | | | | | | T | | | | | T | | | | | | 10 | |
| MTX 160c | | 16 | | | | | | | | | | | 3 | | | 3 | 3 | 3 | | | | | | 3 | | |
| | | 20 | | | | | | | | | | | | 3 | | | 3 | 3 | 3 | | | | | | 3 | |
| | | 25 | | | | | | | | | | | | 3 | | | 3 | 3 | 3 | | | | | | 3 | |
| | | 32 | | | | | | | | | | | | 3 | | | 3 | 3 | | | | | | | 3 | |
| | | 40 | | | | | | | | | | | | 3 | | | 3 | 3 | | | | | | | 3 | |
| | | 50 | | | | | | | | | | | | 3 | | | 3 | 3 | | | | | | | 3 | |
| | | 63 | | | | | | | | | | | | 3 | | | | 3 | | | | | | | 3 | |
| | | 80 | | | | | | | | | | | | | | | | | 3 | | | | | | | |
| | | 100 | | | | | | | | | | | | | | | | | | | | | | | | |
| | | 125 | | | | | | | | | | | | | | | | | | | | | | | | |
| 160 | | | | | | | | | | | | | | | | | | | | | | | | | | |
| MTXE 160 | | 10 | | | | | | | | | | | | | | | | | | | | | | | | |
| | | 25 | | | | | | | | | | | | | | | | | | | | | | | | |
| | | 63 | | | | | | | | | | | | | | | | | | | | | | | | |
| | | 100 | | | | | | | | | | | | | | | | | | | | | | | | |
| | | 160 | | | | | | | | | | | | | | | | | | | | | | | | |
| MTX 250 | | 63 | | | | | | | | | | | | | | | | | | | | | | 3 | | |
| | | 80 | | | | | | | | | | | | | | | | | | | | | | 3 | | |
| | | 100 | | | | | | | | | | | | | | | | | | | | | | | | |
| | | 125 | | | | | | | | | | | | | | | | | | | | | | | | |
| | | 160 | | | | | | | | | | | | | | | | | | | | | | | | |
| | | 200 | | | | | | | | | | | | | | | | | | | | | | | | |
| 250 | | | | | | | | | | | | | | | | | | | | | | | | | | |

Note: T= total selectivity - kA values

For technical information contact the Technical Assistance Service or visit www.gewiss.com

MODULAR CIRCUIT BREAKERS FOR CIRCUIT PROTECTION

| SELECTIVITY TABLE - 400 Vac UPSTREAM - 400 Vac DOWNSTREAM (EN 60947-2) | | | | | | | | | | | | | | | | | | | | | | | | |
|--|-----|---------|-----|-----|-----|-----|-----|---------------|-----|-----|-----|---------|-----|-----|---------------|-----|----------|-----|---------------|------|------|---------------|------|--|
| MTX 250 | | MTX 320 | | | | | | MTXE 320 | | | | MTX 630 | | | MTXE 630 | | MTX 1000 | | MTXE 1000 | | | MTSE 1600 | | |
| TM1 | | TM2 | | | | | | SEP/1 - SEP/2 | | | | TM2 | | | SEP/1 - SEP/2 | | TM2 | | SEP/1 - SEP/2 | | | SEP/A - SEP/B | | |
| 200 | 250 | 100 | 125 | 160 | 200 | 250 | 100 | 160 | 250 | 320 | 320 | 400 | 500 | 400 | 630 | 630 | 800 | 630 | 800 | 1000 | 1000 | 1250 | 1600 | |
| T | T | T | T | T | T | T | T | T | T | T | T | T | T | T | T | T | T | T | T | T | T | T | T | |
| T | T | T | T | T | T | T | T | T | T | T | T | T | T | T | T | T | T | T | T | T | T | T | T | |
| T | T | T | T | T | T | T | T | T | T | T | T | T | T | T | T | T | T | T | T | T | T | T | T | |
| T | T | T | T | T | T | T | T | T | T | T | T | T | T | T | T | T | T | T | T | T | T | T | T | |
| T | T | T | T | T | T | T | T | T | T | T | T | T | T | T | T | T | T | T | T | T | T | T | T | |
| T | T | T | T | T | T | T | T | T | T | T | T | T | T | T | T | T | T | T | T | T | T | T | T | |
| T | T | T | T | T | T | T | T | T | T | T | T | T | T | T | T | T | T | T | T | T | T | T | T | |
| T | T | T | T | T | T | T | T | T | T | T | T | T | T | T | T | T | T | T | T | T | T | T | T | |
| T | T | T | T | T | T | T | T | T | T | T | T | T | T | T | T | T | T | T | T | T | T | T | T | |
| T | T | T | T | T | T | T | T | T | T | T | T | T | T | T | T | T | T | T | T | T | T | T | T | |
| 9,5 | T | T | T | T | T | T | T | T | T | T | T | T | T | T | T | T | T | T | T | T | T | T | T | |
| | T | T | T | T | T | T | T | T | T | T | T | T | T | T | T | T | T | T | T | T | T | T | T | |
| | | T | T | T | T | T | T | T | T | T | T | T | T | T | T | T | T | T | T | T | T | T | T | |
| T | T | T | T | T | T | T | T | T | T | T | T | T | T | T | T | T | T | T | T | T | T | T | T | |
| 9,5 | T | T | T | T | T | T | T | T | T | T | T | T | T | T | T | T | T | T | T | T | T | T | T | |
| | | T | T | T | T | T | T | T | T | T | T | T | T | T | T | T | T | T | T | T | T | T | T | |
| T | T | T | T | T | T | T | T | T | T | T | T | T | T | T | T | T | T | T | T | T | T | T | T | |
| T | T | T | T | T | T | T | T | T | T | T | T | T | T | T | T | T | T | T | T | T | T | T | T | |
| T | T | T | T | T | T | T | T | T | T | T | T | T | T | T | T | T | T | T | T | T | T | T | T | |
| T | T | T | T | T | T | T | T | T | T | T | T | T | T | T | T | T | T | T | T | T | T | T | T | |
| T | T | 6 | T | T | T | T | T | T | T | T | T | T | T | T | T | T | T | T | T | T | T | T | T | |
| T | T | | T | T | T | T | T | T | T | T | T | T | T | T | T | T | T | T | T | T | T | T | T | |
| 4 | 5 | 10 | 10 | 10 | 10 | 10 | 10 | 10 | 10 | 10 | T | T | T | T | T | T | T | T | T | T | T | T | T | |
| 4 | 5 | 10 | 10 | 10 | 10 | 10 | 10 | 10 | 10 | 10 | T | T | T | T | T | T | T | T | T | T | T | T | T | |
| 4 | 5 | 10 | 10 | 10 | 10 | 10 | 10 | 10 | 10 | 10 | T | T | T | T | T | T | T | T | T | T | T | T | T | |
| 4 | 5 | 10 | 10 | 10 | 10 | 10 | 10 | 10 | 10 | 10 | T | T | T | T | T | T | T | T | T | T | T | T | T | |
| 4 | 5 | 10 | 10 | 10 | 10 | 10 | 10 | 10 | 10 | 10 | T | T | T | T | T | T | T | T | T | T | T | T | T | |
| 4 | 5 | | 10 | 10 | 10 | 10 | 10 | 10 | 10 | 10 | T | T | T | T | T | T | T | T | T | T | T | T | T | |
| 4 | 5 | | | 10 | 10 | 10 | | 10 | 10 | 10 | T | T | T | T | T | T | T | T | T | T | T | T | T | |
| | 5 | | | 10 | 10 | 10 | | 10 | 10 | 10 | T | T | T | T | T | T | T | T | T | T | T | T | T | |
| | | | | | 10 | 10 | | | 10 | 10 | T | T | T | T | T | T | T | T | T | T | T | T | T | |
| | | | | | | | | | 10 | 10 | T | T | T | T | T | T | T | T | T | T | T | T | T | |
| 3 | 4 | 25 | 25 | 25 | 25 | 25 | 25 | 25 | 25 | 25 | T | T | T | T | T | T | T | T | T | T | T | T | T | |
| 3 | 4 | 25 | 25 | 25 | 25 | 25 | 25 | 25 | 25 | 25 | T | T | T | T | T | T | T | T | T | T | T | T | T | |
| 3 | 4 | | | 25 | 25 | 25 | 25 | 25 | 25 | 25 | T | T | T | T | T | T | T | T | T | T | T | T | T | |
| 3 | 4 | | | | | 25 | | 25 | 25 | 25 | T | T | T | T | T | T | T | T | T | T | T | T | T | |
| 3 | 4 | | | | | | | | 25 | 25 | T | T | T | T | T | T | T | T | T | T | T | T | T | |
| 4 | 5 | | 7 | 7 | 7 | 7 | 7 | 7 | 7 | 7 | 25 | 25 | 25 | 25 | 25 | T | T | T | T | T | T | T | T | |
| 4 | 5 | | | 7 | 7 | 7 | | 7 | 7 | 7 | 25 | 25 | 25 | 25 | 25 | T | T | T | T | T | T | T | T | |
| 4 | 5 | | | 7 | 7 | 7 | | 7 | 7 | 7 | 25 | 25 | 25 | 25 | 25 | 40 | T | 40 | T | T | T | T | T | |
| | | | | | 7 | | | | 7 | 7 | 20 | 20 | 20 | 20 | 20 | 36 | T | 36 | T | T | T | T | T | |
| | | | | | | | | | 7 | 7 | | | 20 | 20 | 20 | 36 | T | 36 | T | T | T | T | T | |
| | | | | | | | | | | 7 | | | | 20 | 20 | 30 | T | 30 | T | T | T | T | T | |
| | | | | | | | | | | | | | | 20 | 20 | 30 | 40 | 30 | 40 | 40 | T | T | T | |

For technical information contact the Technical Assistance Service or visit gewiss.com

MODULAR CIRCUIT BREAKERS FOR CIRCUIT PROTECTION

Protection of lighting circuits

Determining the rated current of the circuit breaker

To select the most suitable rated current of the miniature circuit breaker for lighting circuit protection, it is necessary to know the operating current provided by the lighting device manufacturer, or calculated on the basis of the type of lamp and the relative technical data (rated power, power supply voltage and power factor). Once the operating current is known, you should choose the circuit breaker version with the rated current value immediately above this value. The tables below show the maximum number of lamps that can be protected, on the basis of the rated current. For all case, you are advised to choose a circuit breaker with tripping characteristic C.

| SINGLE-PHASE 230V AC - THREE-PHASE DISTRIBUTION 400V AC WITH NEUTRAL ⁽¹⁾ | | | | | | | | | | | | | | |
|---|----------------|--|----|----|-----|-----|-----|-----|-----|-----|-----|-----|-----|-----|
| Rated current In (A): | | 6 | 10 | 13 | 16 | 20 | 25 | 32 | 40 | 50 | 63 | 80 | 100 | 125 |
| FLUORESCENT lamps | Lamp power (W) | Number of lamps per phase | | | | | | | | | | | | |
| | | Single without P.F. correction (cos = 0.6) | 18 | 24 | 36 | 61 | 79 | 98 | 122 | 153 | 196 | 245 | 306 | 386 |
| | 36 | 12 | 18 | 30 | 39 | 49 | 61 | 76 | 98 | 122 | 153 | 193 | 245 | 306 |
| | 58 | 7 | 11 | 19 | 24 | 30 | 38 | 47 | 60 | 76 | 95 | 119 | 152 | 190 |
| Single with P.F. correction (cos = 0.86) ⁽²⁾ | 18 | 35 | 52 | 87 | 114 | 140 | 175 | 219 | 281 | 351 | 439 | 553 | 703 | 879 |
| | 36 | 17 | 26 | 43 | 57 | 70 | 87 | 109 | 140 | 175 | 219 | 276 | 351 | 439 |
| | 58 | 10 | 16 | 27 | 35 | 43 | 54 | 68 | 87 | 109 | 136 | 171 | 218 | 272 |
| Double with P.F. correction (cos = 0.86) ⁽²⁾ | 2 x 18 | 17 | 26 | 43 | 57 | 70 | 87 | 109 | 140 | 175 | 219 | 276 | 351 | 439 |
| | 2 x 36 | 8 | 13 | 21 | 28 | 35 | 43 | 54 | 70 | 87 | 109 | 138 | 175 | 219 |
| | 2 x 58 | 5 | 8 | 13 | 17 | 21 | 27 | 34 | 43 | 54 | 68 | 85 | 109 | 136 |









⁽¹⁾ Star connection

⁽²⁾ The values given are valid for lamps with inductive ballast and starter. In the case of lamps with an electronic power supply, the number of lamps indicated should be halved

| THREE-PHASE DISTRIBUTION 230V AC and 400V AC ⁽³⁾ | | |
|---|--------------------------|----------------|
| DISCHARGE lamps | Power (W) ⁽⁴⁾ | Current In (A) |
| Mercury vapor lamp | ≤ 700 | 6 |
| | ≤ 1000 | 10 |
| | ≤ 2000 | 16 |
| Metal halide lamp | ≤ 375 | 6 |
| | ≤ 1000 | 10 |
| | ≤ 2000 | 16 |
| High pressure sodium vapor lamp | ≤ 400 | 6 |
| | ≤ 1000 | 10 |

⁽³⁾ With ballast with or without P.F. correction, and star or delta connection

⁽⁴⁾ The values given refer to the maximum values for each start-up

| SINGLE PHASE DISTRIBUTION 230 V a.c. | | | | | | | | | | | | | | | | |
|--------------------------------------|------|---|------------------------|----|----|----|----|----|----|----|----|-----|-----|-----|-----|-----|
| Tripping characteristic C | | | | | | | | | | | | | | | | |
| Rated current In (A) | | | 6 | 10 | 13 | 16 | 20 | 25 | 32 | 40 | 50 | 63 | 80 | 100 | 125 | |
| SMART LED lamps | | Lamp power (W) | Number lamps per phase | | | | | | | | | | | | | |
| SMART [4] - LB | 2L |  | 31 | - | 10 | 17 | 23 | 32 | 44 | 59 | 78 | 100 | 129 | 168 | 214 | 270 |
| | 2+2L |  | 62 | - | 6 | 10 | 14 | 19 | 26 | 35 | 46 | 59 | 76 | 99 | 126 | 159 |
| | 4L |  | 62 | - | 6 | 10 | 14 | 19 | 26 | 35 | 46 | 59 | 76 | 99 | 126 | 159 |
| | 5L |  | 69 | - | 4 | 7 | 10 | 14 | 19 | 26 | 34 | 44 | 57 | 74 | 94 | 119 |
| SMART [4] - HB | 4+4L |  | 124 | - | 3 | 5 | 7 | 9 | 13 | 17 | 23 | 29 | 38 | 49 | 63 | 79 |
| | 5+5L |  | 138 | - | 2 | 3 | 5 | 7 | 9 | 13 | 17 | 22 | 28 | 37 | 47 | 59 |
| | 4x4L |  | 248 | - | 1 | 2 | 3 | 4 | 6 | 8 | 11 | 14 | 19 | 24 | 31 | 39 |
| | 4x5L |  | 276 | - | - | 1 | 2 | 3 | 4 | 6 | 8 | 11 | 14 | 18 | 23 | 29 |

For technical information contact the Technical Assistance Service or visit gewiss.com

Dimension tables

MTC 45 - MTC 60 - MTC 100

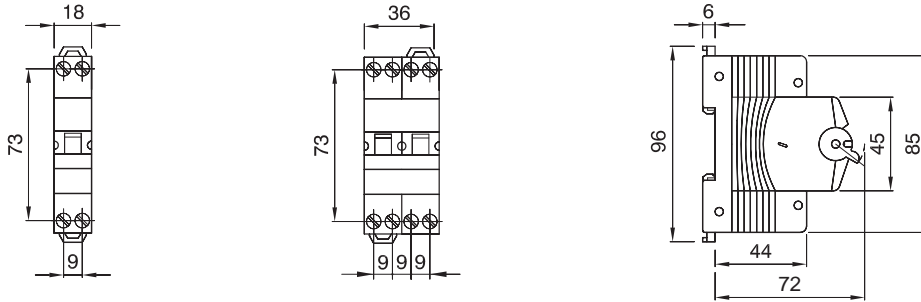

MT45 - MT 60 - MT 100 - MT 250

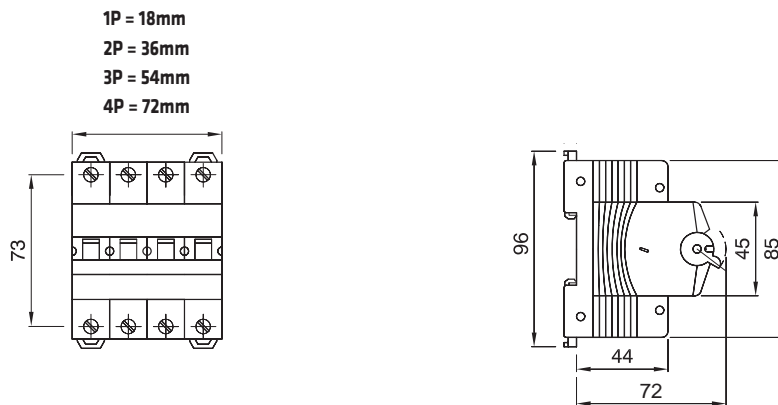

MTHP 160 - MTHP 250

