

90 MCB RANGE

MODULAR DEVICES FOR CIRCUIT PROTECTION



90 MCB RANGE

TECHNICAL DATA

TYPE	MTC			MT			
	MTC 45	MTC 60	MTC 100	MT 45	MT 60		
Rated current (In): (A)	2-32	6-32	6-32	1-40	1-63		
Utilization category:	A	A	A	A	A		
Rated operational voltage (Ue): (V)	230/400	230/400	230	230/400	230/400		
Minimum operating voltage (Ue min): (V)	12 AC/DC	12 AC/DC	12 AC/DC	12 AC/DC	12 AC/DC		
Maximum operating voltage (Ue max): (V)	440AC / 220DC	440AC / 220DC	253AC / 110 DC	440 AC / 220 DC	440 AC / 220 DC		
Rated insulation voltage (Ui): (V)	500	500	500	500	500		
Rated frequency: (Hz)	50/60	50/60	50/60	50/60	50/60		
Rated impulse withstand voltage (Uimp): (kV)	4	4	4	4	4		
Number of poles:	1 1+N 2,3,4	1+N, 2 3, 4	1+N, 2	1, 1+N 2,3,4	1, 1+N 2,3,4		
AC - Alternating Current - IEC 60898 - EN 60898 (A)							
Breaking capacity	lcn	4500	6000	10000 ⁽¹⁾	4500	6000	
	lcs	1 lcn	1 lcn	0.75 lcn	1 lcn	1 lcn	
	AC - Alternating Current - IEC 60947-2 - EN 60947-2 [kA] Ue (V)						
	lcu	230/240	4.5 6 6	7,5 10	10	4.5 6	10 20
		400/415	4.5 4,5	6 (2P) 6		4.5 6	10 (1P) 10
	lcs	100% lcu		75% lcu	75% lcu	100% lcu	
	DC - Direct Current - IEC 60947-2 - EN 60947-2 [kA] Ue (V)						
	lcu (1 pole) 50	6		10		6	10
		lcs		6	10	6	10
	lcu (2 poles in series) 110	6		10	10 (15 to 50V)	6	10
lcs		6	10	6	6		
lcu (4 poles in series) 220	4.5		6		4.5	10	
	lcs		4.5	6	2.5	10	
Wiring: cable section (mm ²)	rigid	≤ 16		≤ 16	≤ 35		
	flexible	≤ 10		≤ 10	≤ 25		
Electrical endurance (number of O-C cycles)	10000		10000	10000	10000		
Max. No. of usable modular accessories	3		3	3	3		
Upline/downline power supply	yes		yes	yes	yes		
Isolating displayed	yes		yes	yes	yes		
Type of RCCB	-		-	-	Add-on RCD - BD	Add-on RCD - BD	
Rated tightening torque: (Nm)	1.2		1.2	1.2	2	2	
Degree of protection for	terminals (with terminal covers)	IP40		IP40	IP40		
	other parts	IP40		IP40	IP40		
Tropicalisation	55°C - RH 95%		55°C - RH 95%	55°C - RH 95%	55°C - RH 95%		
Operating temperature (°C)	-25 +60		-25 +60	-25 +60	-25 +60		
Reference temperature (°C)	30		30	30	30		
Curves	C		C B	C	C B	C B D	
Rated currents available In (A)					1		
					2		
					3		
					4		
	6		6 6	6	6 6	6 6 6	
	10		10 10	10	10 10	10 10 10	
	13		13 13	13	13 13	13 13 13	
	16		16 16	16	16 16	16 16 16	
	20		20 20	20	20 20	20 20 20	
	25		25 25	25	25 25	25 25 25	
	32		32 32	32	32 32	32 32 32	
					40 40	40 40 40	
						50 50	
						63 63	

⁽¹⁾ Breaking capacity of single pole lcn=6000A

FEATURES OF THE NEW MECHANISM OF THE MTC COMPACT CIRCUIT BREAKERS

The position of the magnetic releases on the front of circuit breaker with opposing magnetic turns and opposing arc chute chambers, allows to reduce specific let-through energy and short-circuit stresses on the mechanism substantially. It has thus been possible to halve the number of modules and lighten the mechanism which has short pre-arcing times due to the lower specific let-through power. The new mechanism has been sized and optimised by means of a sophisticated planning, engineering and testing programme.

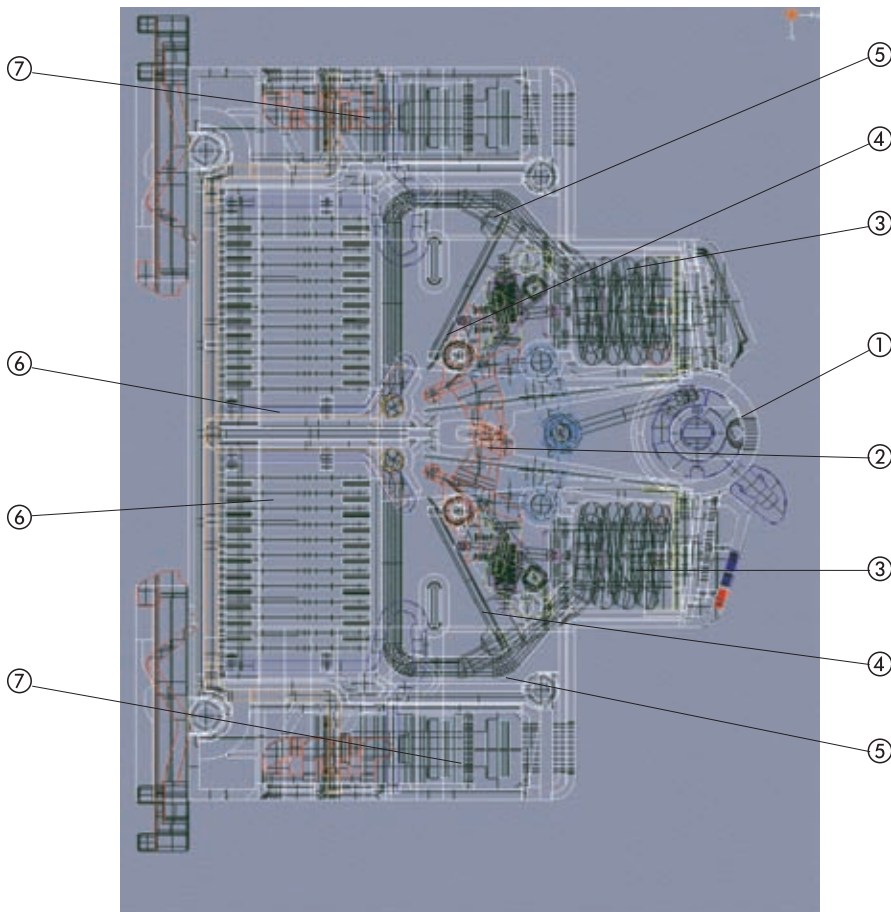

- ① Manual control lever with consistent position with the internal contacts, allows the circuit breaker to be used as switch-disconnector
- ② Toggle joint trip mechanism with trip accelerator for short-circuit condition
- ③ Electromagnet for instantaneous short-circuit tripping
- ④ Silver-graphite contacts to maintain electrical characteristics over time
- ⑤ Magnetic turns in the arc chute chambers
- ⑥ Arc chute chambers with 12 dejon splitter plates
- ⑦ Shell-type terminals with anti-loosening tightening system

BEHAVIOUR WITH CHEMICAL AND ATMOSPHERIC AGENTS

Agent	Saline solution	Acids		Bases		Solvents				Mineral oil	UV rays
		Concentrated	Diluted	Concentrated	Diluted	Hexane	Benzol	Acetone	Alcohol		
Resistance	Resistant	Limited resistance	Resistant	Limited resistance	Resistant	Resistant	Limited resistance	Limited resistance	Limited resistance	Resistant	Resistant

POWER LOSS VALUES AND TEMPERATURE PERFORMANCE

MTC 45 - 60 - 100 COMPACT MINIATURE CIRCUIT BREAKERS

General characteristics

The MTC range, compact miniature circuit breakers, is distinguished by the small amount of space taken up in the enclosure and by full modularity with electrical auxiliaries and modular accessories. Therefore, it is possible to place all equipment necessary to protect and control the service electrical system centrally, in small spaces. The innovations are based on a new mechanism for circuit breaker operation enclosed in the world-wide GEWISS patent which makes it possible to increase normal performance whilst decreasing the space taken up by 50%. This new device makes it possible to include two-poles protected into a single 18 mm module width with release both magnetic and thermal.

Temperature performance

In planning situations where ambient temperature is higher than the reference temperature of 30°C, the circuit breakers may be subject to untimely tripping, i.e. opening when it is not required, because the rise in temperature is interpreted as overcurrent. In fact ambient temperature affects the initial deformation of the bimetal. With a temperature above 30°C the thermal release trips faster, behaviour like a relay with a lower rated current.

It is therefore imperative to take into consideration the temperature performance at rated current if the circuit breaker is installed in an ambient with a temperature above 30°. The following tables show the max. operating currents corresponding to the different temperatures.

MTC 45 - 60 - 100 COMPACT MINIATURE CIRCUIT BREAKERS						
In (A)	Temperature					
	10°C	20°C	30°C	40°C	50°C	60°C
2	2.1	2.05	2	1.9	1.8	1.55
6	7.2	6.6	6	5.7	5.3	5
10	11.8	10.8	10	9.6	9.1	8.6
13	15	14	13	12.4	11.7	11
16	18.2	17.2	16	15.2	14.3	13.4
20	22.8	21.4	20	19.5	18.9	18.4
25	28.5	26.8	25	24	23	22
32	36.5	34.2	32	30.8	29.5	28.8

Temperature performance for installations in enclosures with degree of protection higher than IP54 needs to multiply the current values written in the table by a coefficient of 0.7.

Power loss per single pole

The following table details power loss values for MTC, compact miniature circuit breakers, in order to allow checking of overtemperature values inside the distribution board in compliance with EN 60439 and IEC 60890 Standards.

MTC 45 - 60 - 100 COMPACT MINIATURE CIRCUIT BREAKERS																
In (A)	2		6		10		13		16		20		25		32	
	Pole	N	Pole	N	Pole	N	Pole	N	Pole	N	Pole	N	Pole	N	Pole	N
R (mΩ)	450	1.07	29.4	2.6	20.3	2.6	14.2	2.6	8.7	2.6	5.7	2.6	5.3	2.6	3.4	2.6
P (W)	1.8	0.04	1.06	0.09	2.03	0.26	2.4	0.44	2.22	0.67	2.27	1.04	3.34	1.63	3.45	2.66

POWER LOSS VALUES AND TEMPERATURE PERFORMANCE

MT 45 - 60 - 100 - 250 MINIATURE CIRCUIT BREAKERS

General characteristics

Thanks to a wide range of articles and high performance, MT miniature circuit breakers allow the installation of electrical systems for which using only MTC range could be unsatisfactory.

The MT range, with rated current from 1 to 63A, B, C and D curves and breaking capacity of 4.5, 6, 10 and 25 kA, can satisfy the installation needs in the commercial, advanced commercial and industrial sectors. In the end, for all MT range, it is possible to use all electric auxiliary devices and modular accessories belonging to 90 AM range.

MT 45 - 60 - 100 - 250 TEMPERATURE PERFORMANCE						
In (A)	Temperature (°C)					
	15	20	30	40	50	60
1	1.07	1.04	1.00	0.97	0.93	0.90
2	2.14	2.07	2.00	1.93	1.86	1.79
3	3.21	3.11	3.00	2.90	2.79	2.69
4	4.28	4.14	4.00	3.86	3.72	3.58
6	7	6.67	6.00	5.52	4.84	3.96
10	11.2	10.8	10.0	8.9	7.95	7.16
13	14.4	13.9	13.0	11.9	10.9	10
16	17.6	17.1	16.0	14.9	13.9	12.8
20	22	21.3	20.0	17.8	16.1	15.1
25	28.2	27.1	25.0	23.4	21.3	18.8
32	37	35.3	32.0	30.8	27.8	23.1
40	45	43.3	40.0	34.8	30	28
50	57.5	55	50.0	46.7	42.1	36.3
63	70	67.7	63.0	59.9	52.7	41.25

MT 45 - 60 - 100 - 250 POWER LOSS PER SINGLE POLE						
In (A)	Curves					
	B		C		D	
	P (W)	R (mΩ)	P (W)	R (mΩ)	P (W)	R (mΩ)
1	-	-	2.20	2200	-	-
2	-	-	2.70	675	-	-
3	-	-	2.30	256	-	-
4	-	-	2.20	138	-	-
6	1.42	39	1.42	39	0.80	22
10	2.13	21	2,13	21	1.20	12
13	2.1	12.4	2.1	12.4	1.3	7.7
16	2.80	11	2.80	11	1.60	6.3
20	2.56	6.4	2.56	6.4	2.10	5.3
25	3.10	5	3.10	5	2.00	3.2
32	3.00	2.9	3.00	2.9	2.40	2.4
40	3.10	1.9	3.10	1.9	2.70	1.7
50	3.87	1.5	3.87	1.5	-	-
63	4.51	1.2	4.51	1.2	-	-

MTHP 160 - 250 HIGH PERFORMANCE MINIATURE CIRCUIT BREAKERS

General characteristics

Thanks to a wide range of articles and high performance, MTHP high performance miniature circuit breakers allow the installation of electrical systems for which using only MTC and MT range could be unsatisfactory.

The MTHP range, with rated current from 20 to 125A, C and D curves and breaking capacity of 10 and 25 kA, can satisfy the installation needs in the commercial, advanced commercial and industrial sectors. In the end, for all MTHP range, it is possible to use all electric auxiliary devices and modular accessories belonging to 90 AM range.

MTHP 160 - 250 TEMPERATURE PERFORMANCE					
In (A)	Temperature				
	20°C	30°C	40°C	50°C	60°C
20	21	20	17,5	16	15
25	26	25	24	22	19
32	35	32	30	28	23
40	42	40	35	33	28
50	55	50	47	42	36
63	66	63	59	53	48
80	85	80	75	70	63
100	107	100	93	87	78
125	135	125	115	107	97

MTHP 160 - 250 POWER LOSS PER SINGLE POLE									
In (A)	20	25	32	40	50	63	80	100	125
	Power loss (W per pole)								
MTHP 250	2.8	2.7	3.1	3.5	4.2	5.6	-	-	-
MTHP 160	-	-	-	-	-	5.6	5.6	7.4	11

CHARACTERISTIC CURVES

TRIPPING CURVES (EN 60898)

MTC 45 - 60 - 100 C curve
 MT 45 - 60 - 100 - 250 C curve
 MTHP 160 - 250 C curve
 MDC 45 - 60 - 100 C curve

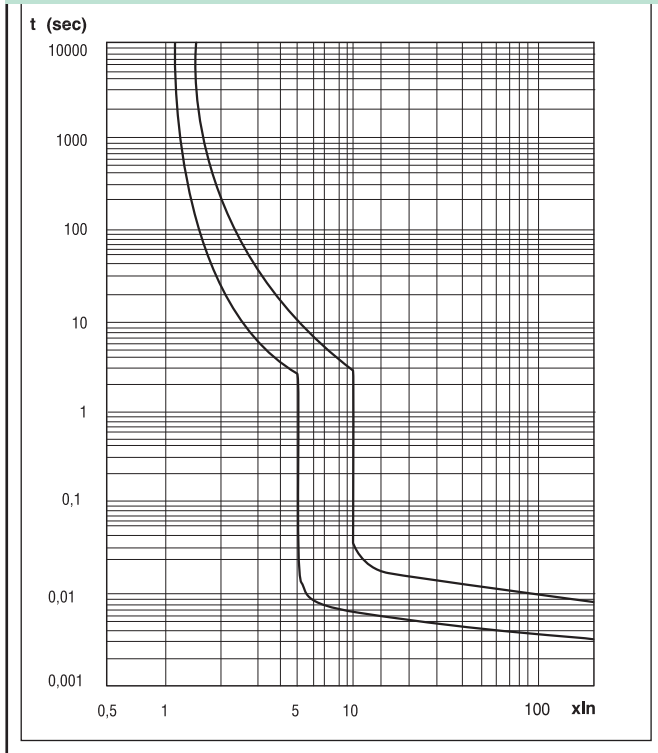

MTC 60 B curve
 MT 45 - 60 - 100 B curve
 MDC 60 - 100 B curve

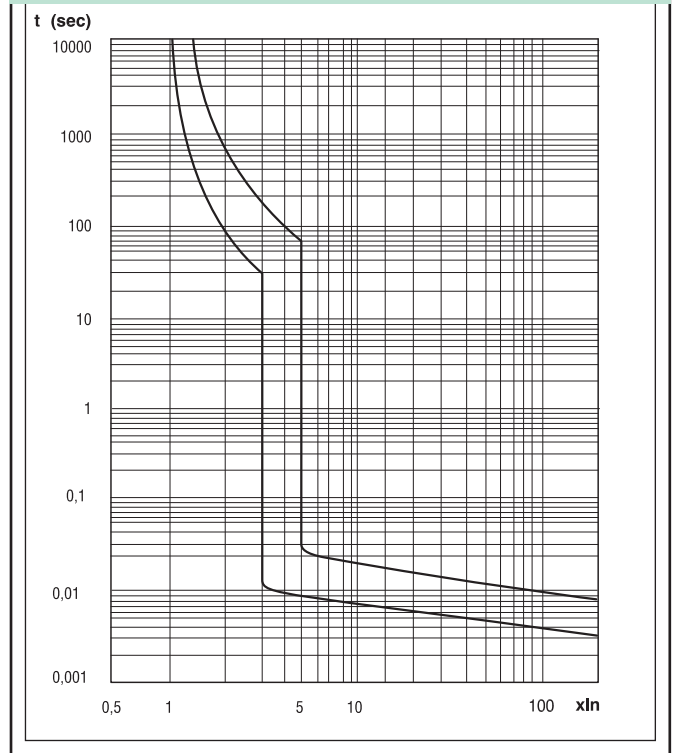

MT 60 - 100 D curve
 MTHP 160 D curve

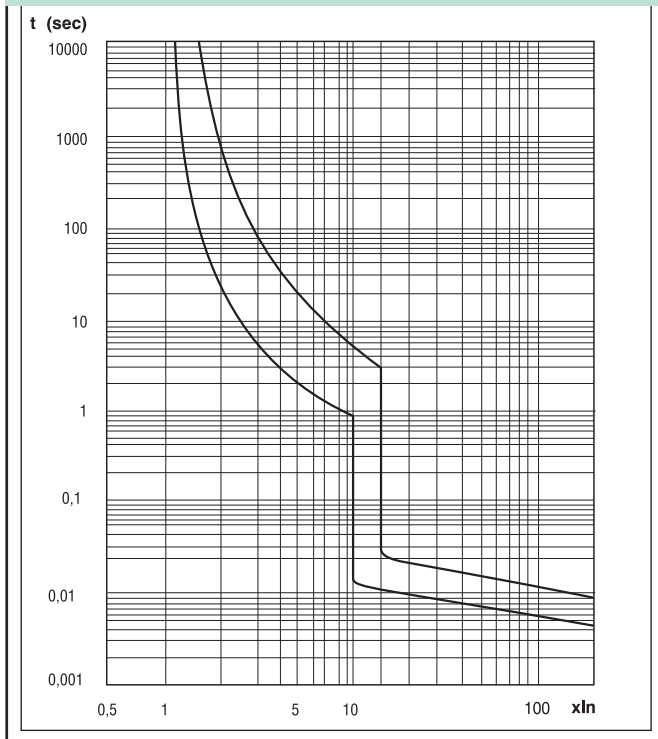

90 MCB RANGE

MODULAR DEVICES FOR CIRCUIT PROTECTION



90 MCB RANGE

MTC SPECIFIC LET-THROUGH ENERGY CURVES

MTC 45 - 1P+N, 2P - 230V versions

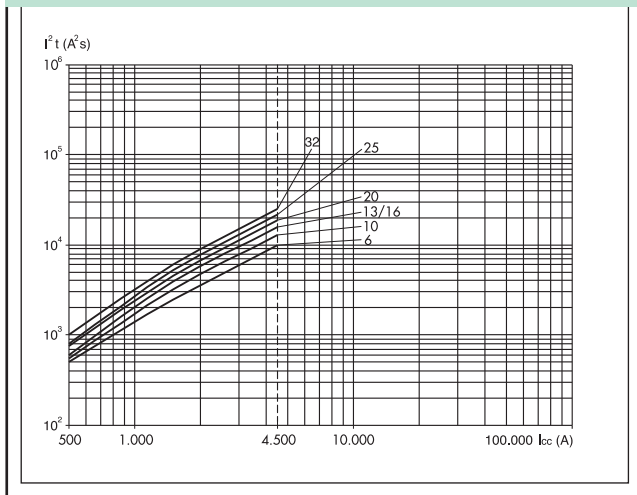

MTC 45 - 1P, 3P, 4P - 230/400V and 2P - 400V versions

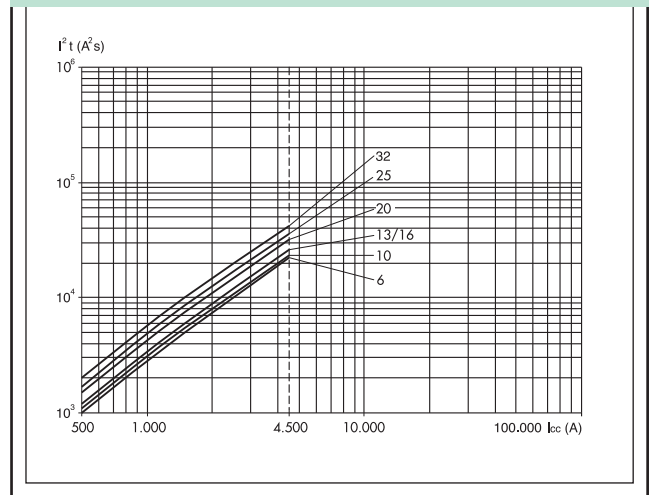

MTC 60 - 1P+N, 2P - 230V versions

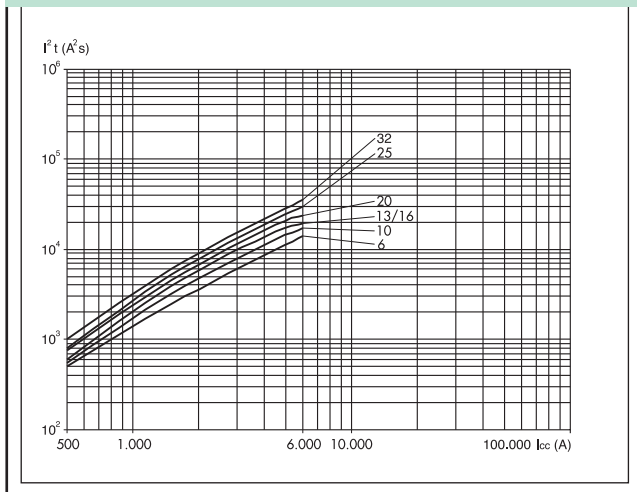

MTC 60 - 1P, 3P, 4P - 230/400V and 2P - 400V versions

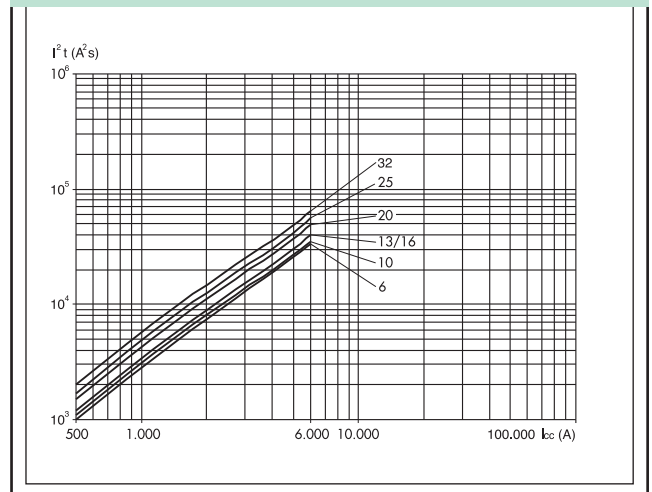

MTC 100 - 1P+N, 2P - 230V versions

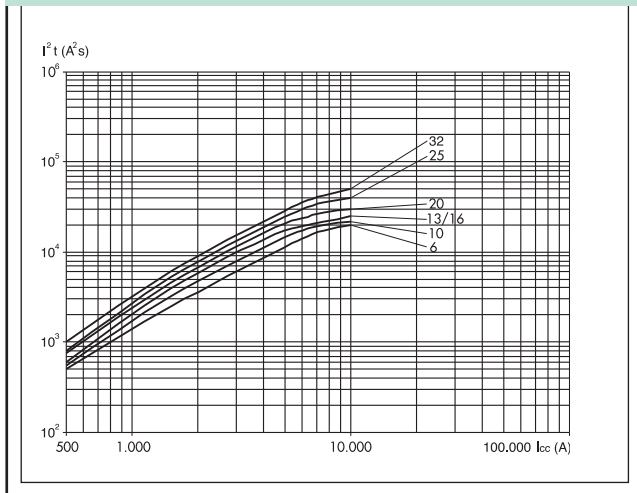

MT 45 SPECIFIC LET-THROUGH ENERGY CURVES

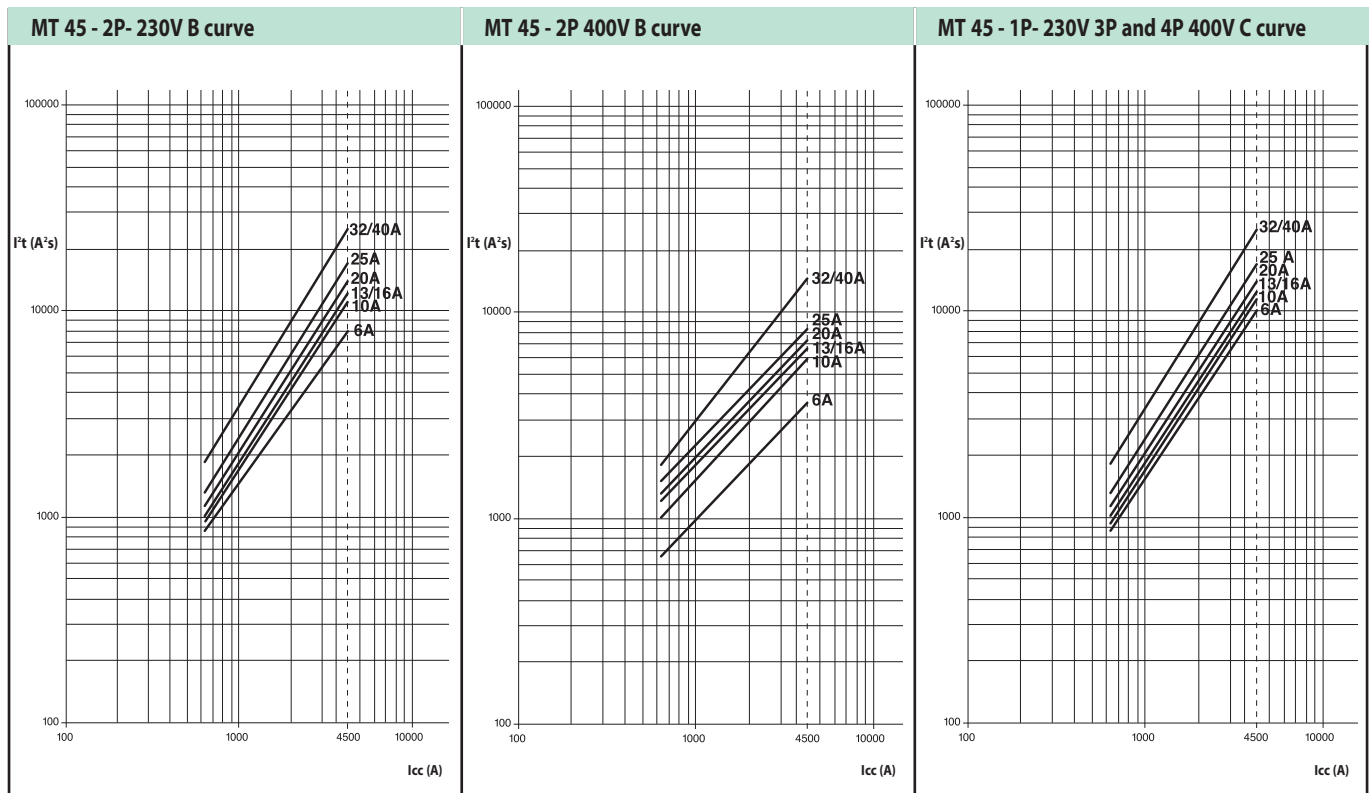
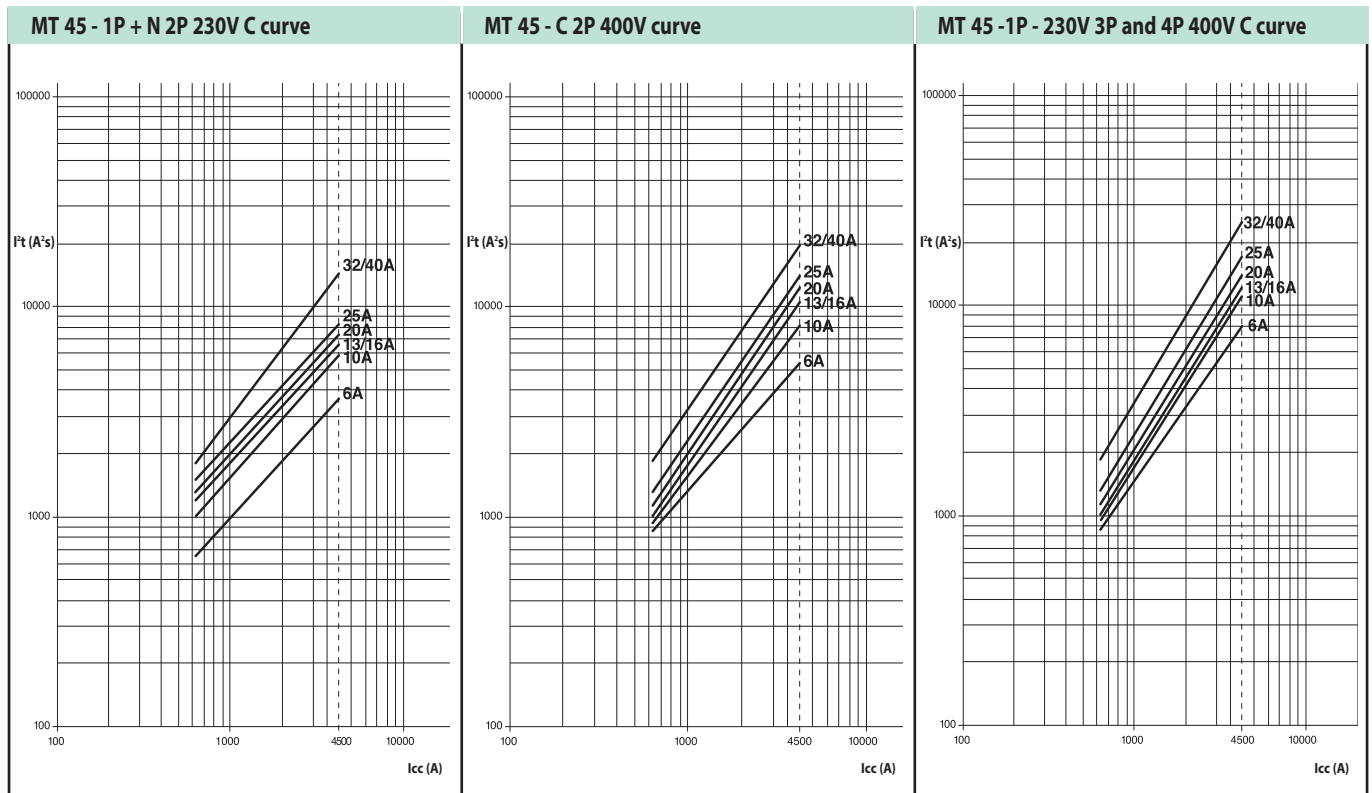

90 MCB RANGE

MODULAR DEVICES FOR CIRCUIT PROTECTION



90 MCB RANGE

MT 60 SPECIFIC LET-THROUGH ENERGY CURVES

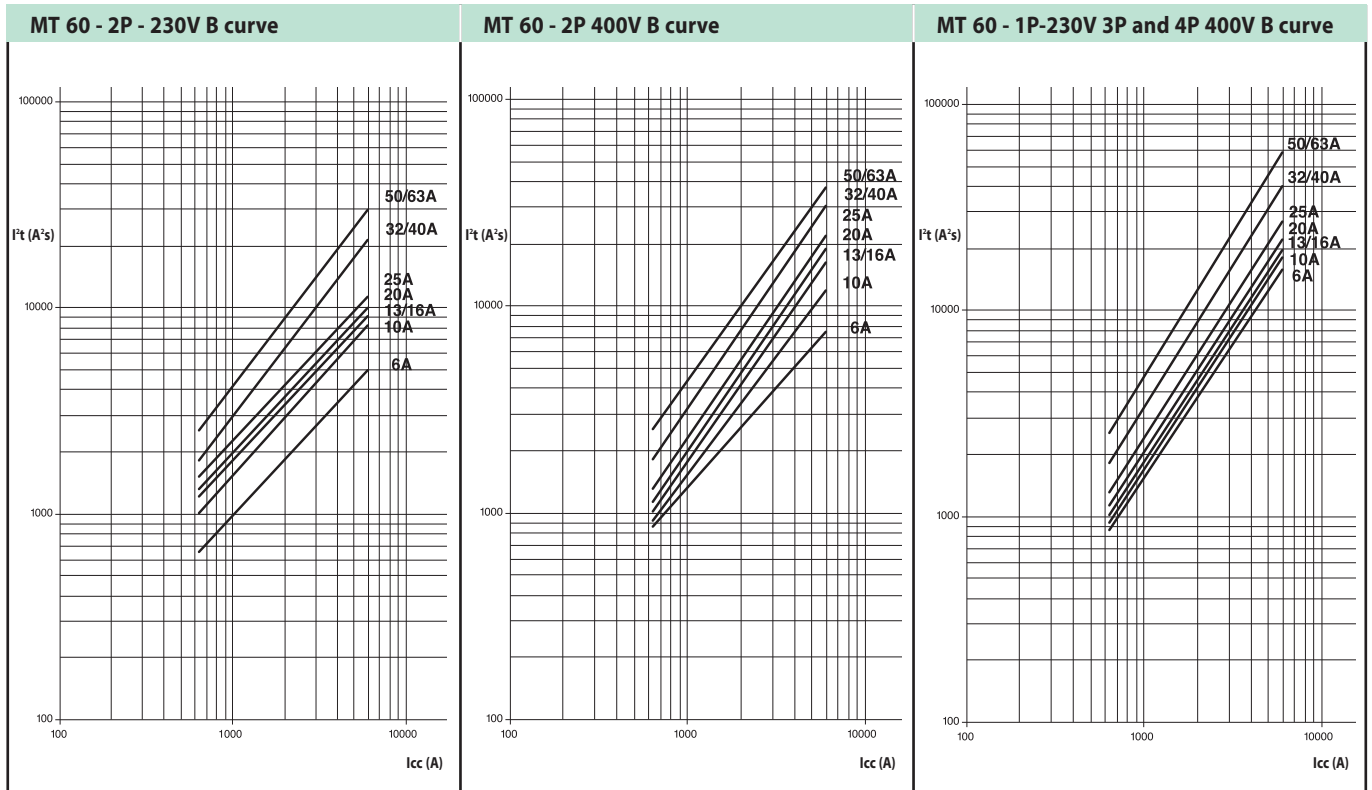
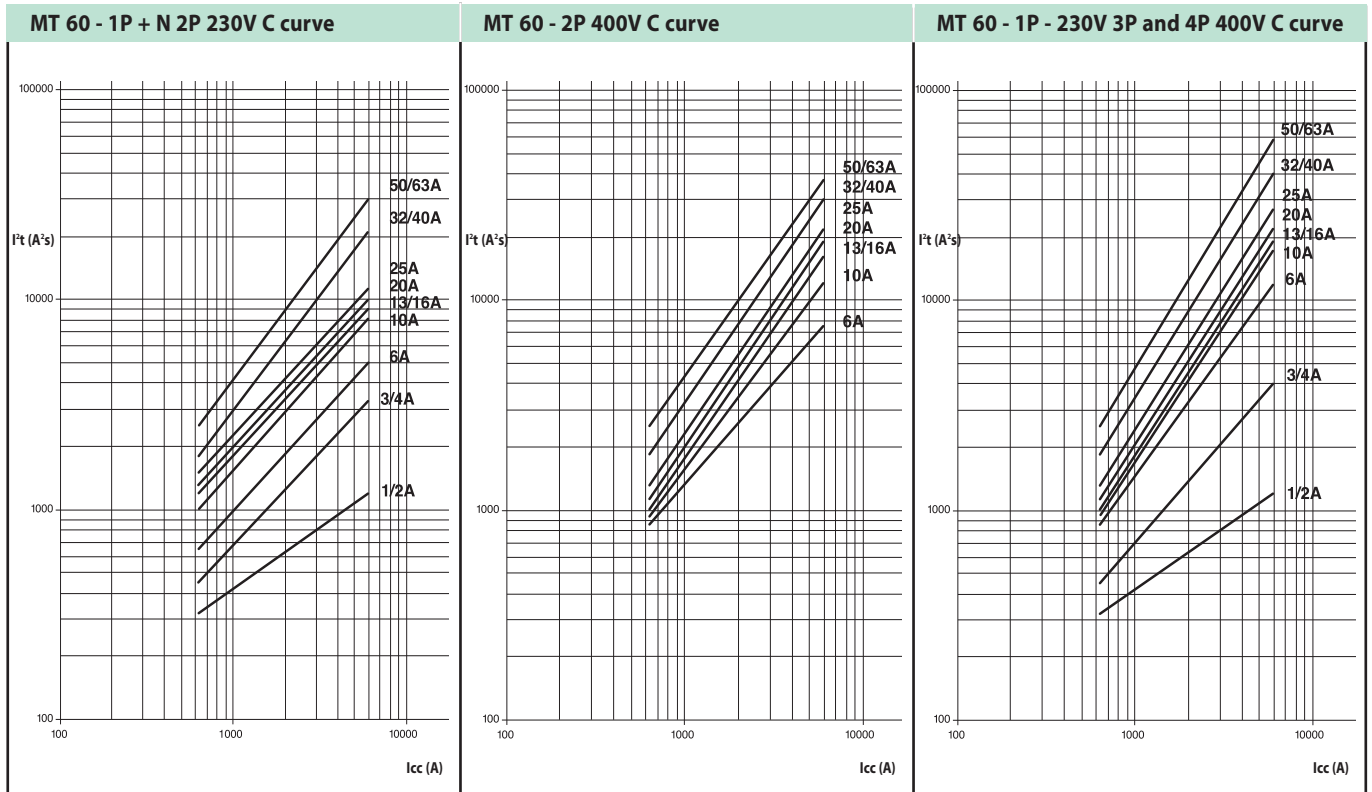

90 MCB RANGE

MODULAR DEVICES FOR CIRCUIT PROTECTION



MT 60 - 100 SPECIFIC LET-THROUGH ENERGY CURVES

90 MCB RANGE

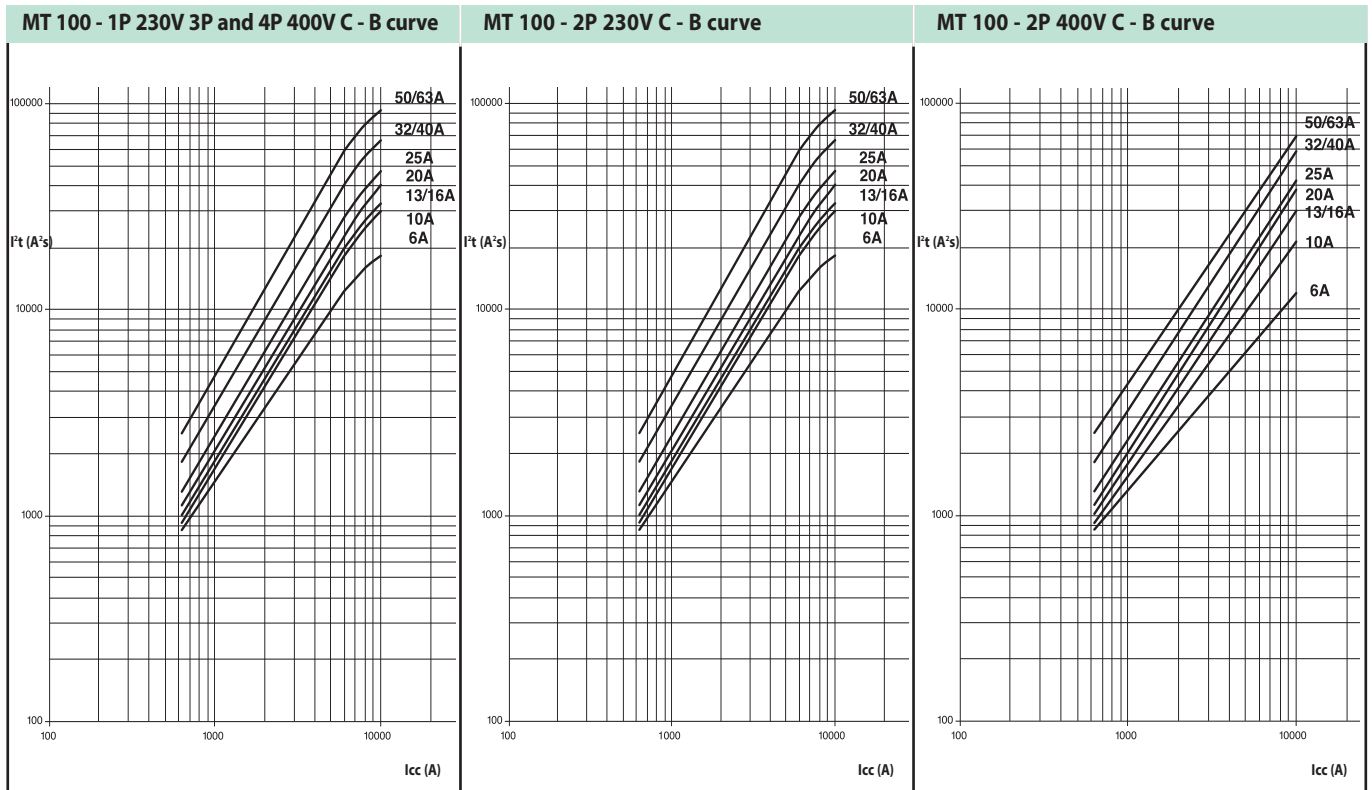
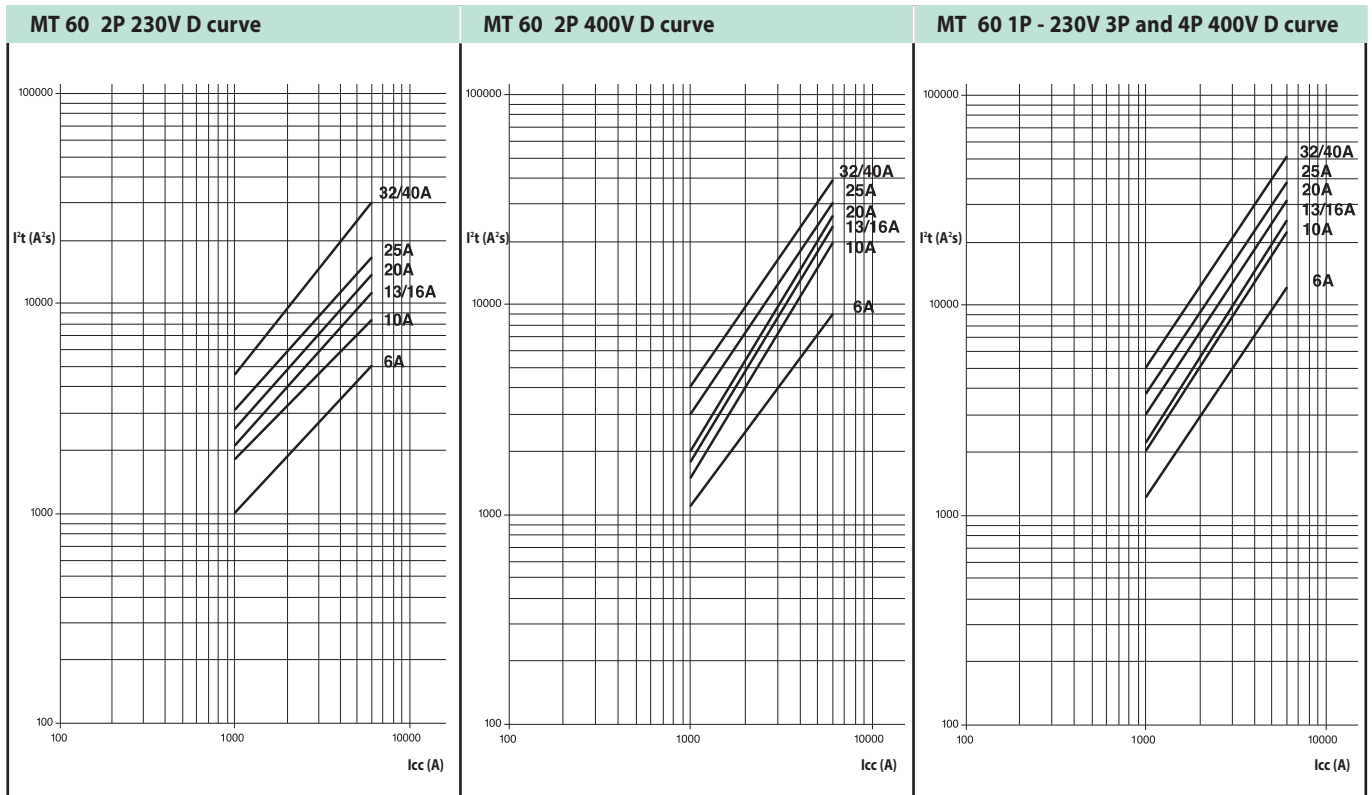

90 MCB RANGE

MODULAR DEVICES FOR CIRCUIT PROTECTION



90 MCB RANGE

MT 100 - 250 SPECIFIC LET-THROUGH ENERGY CURVES

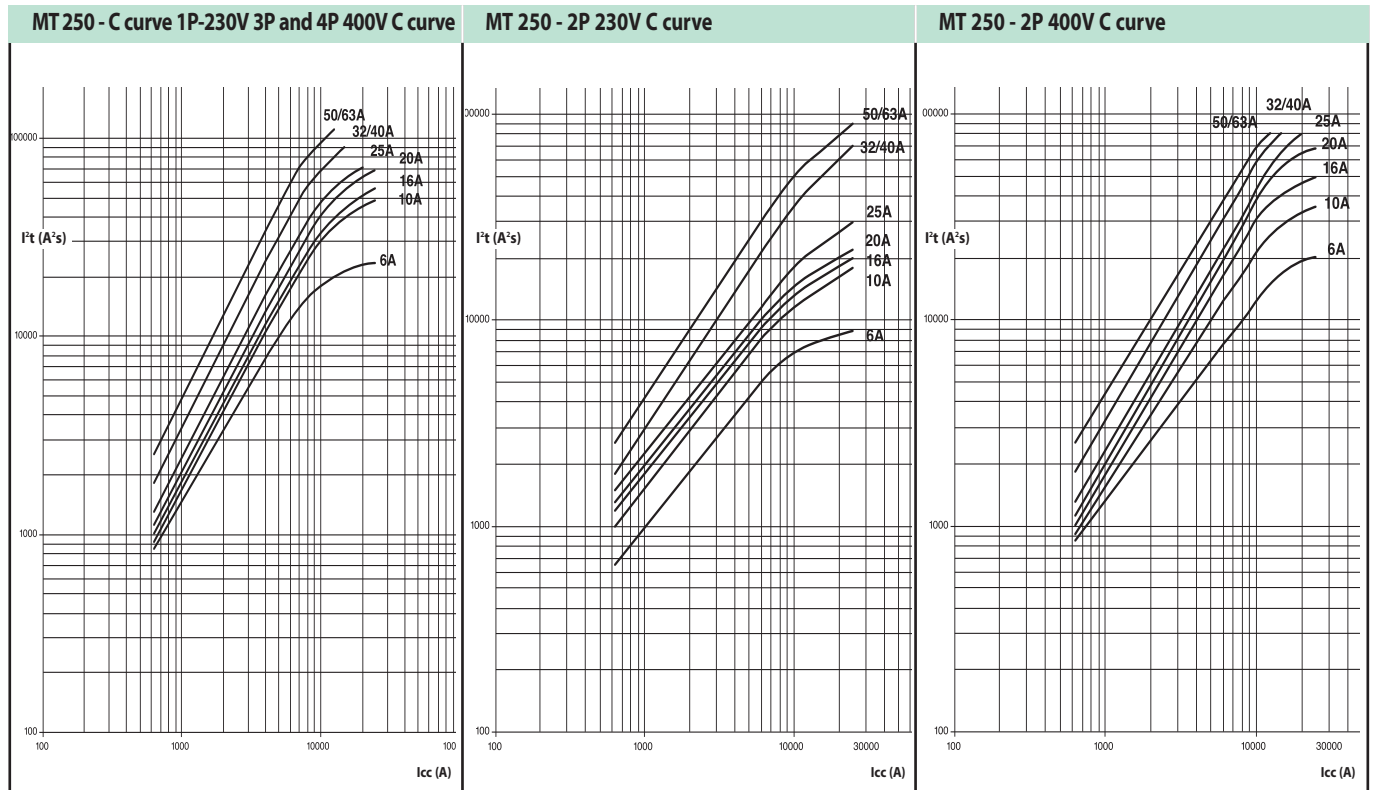
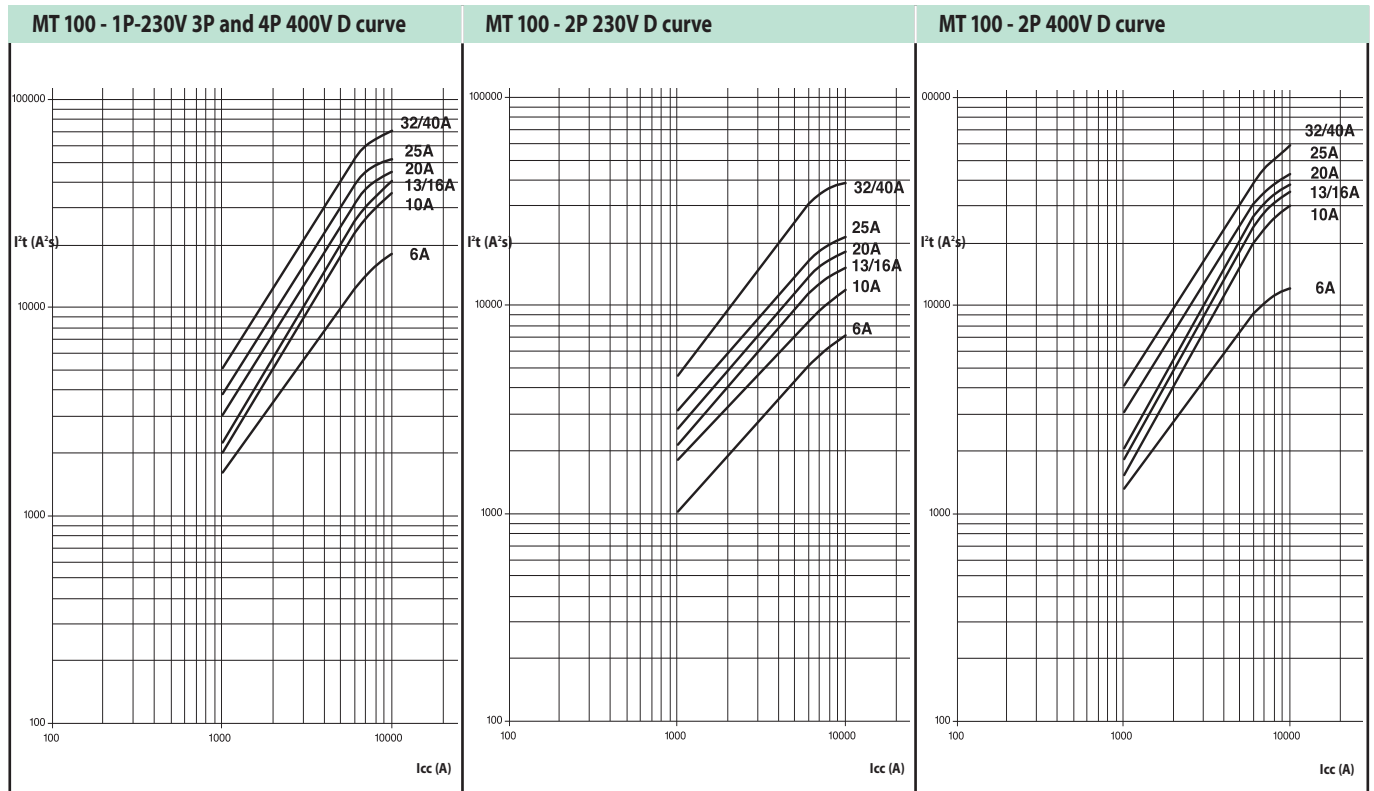

90 MCB RANGE

MODULAR DEVICES FOR CIRCUIT PROTECTION



MTHP 250 SPECIFIC LET-THROUGH ENERGY CURVES

90 MCB RANGE

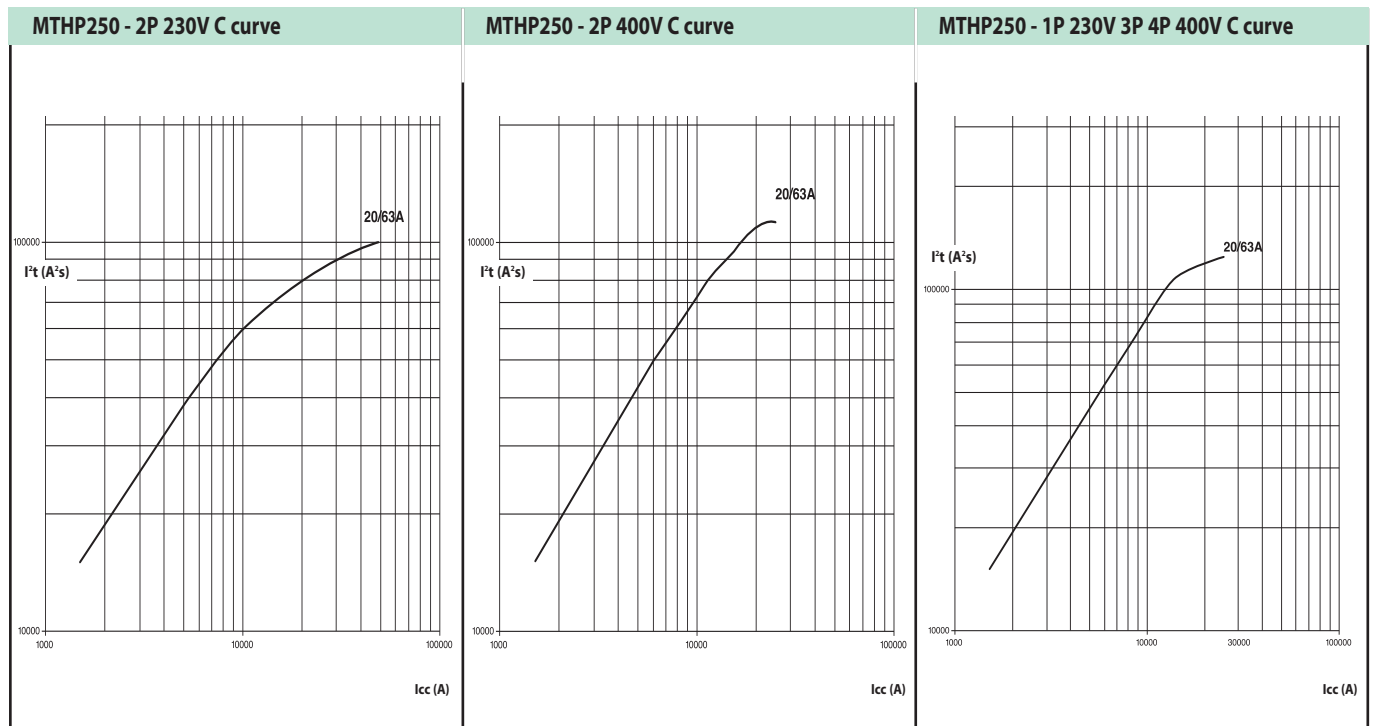

MTHP 160 SPECIFIC LET-THROUGH ENERGY CURVES

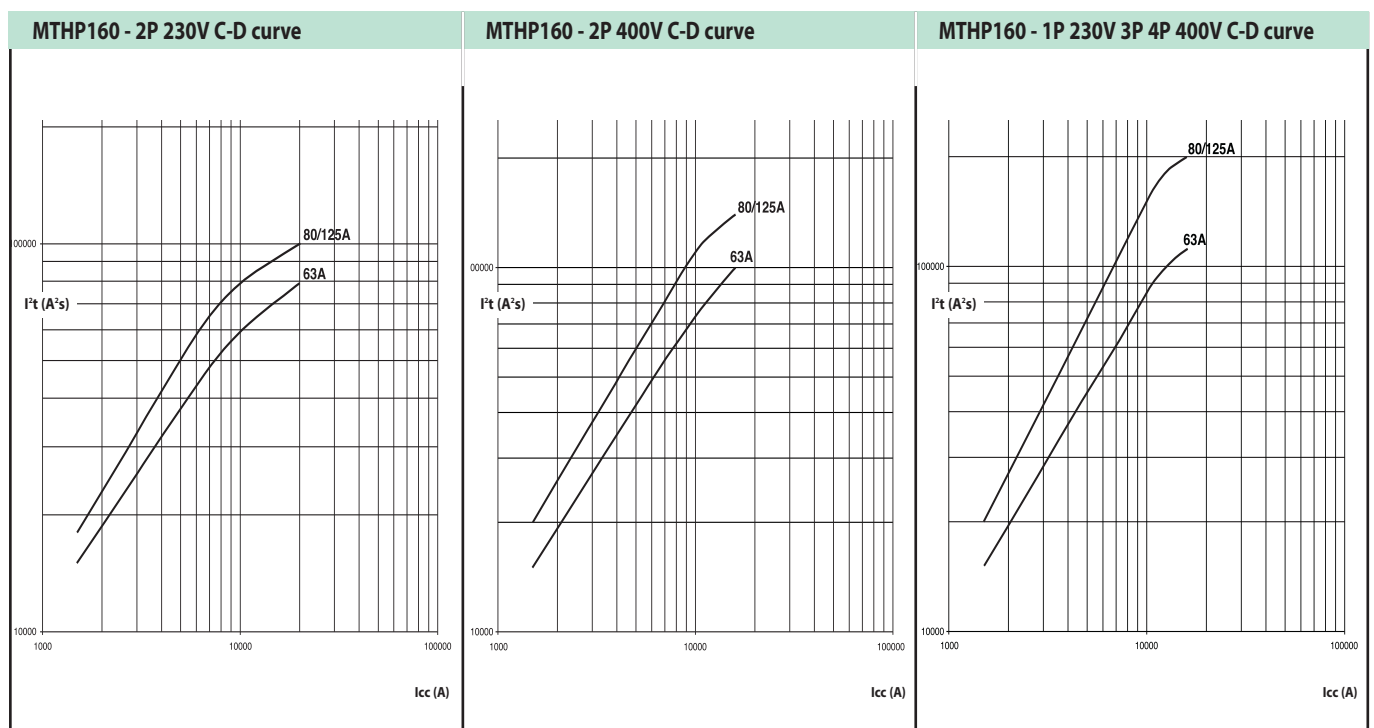

90 MCB RANGE

MODULAR DEVICES FOR CIRCUIT PROTECTION



90 MCB RANGE

PEAK CURRENT LIMITATION CURVES

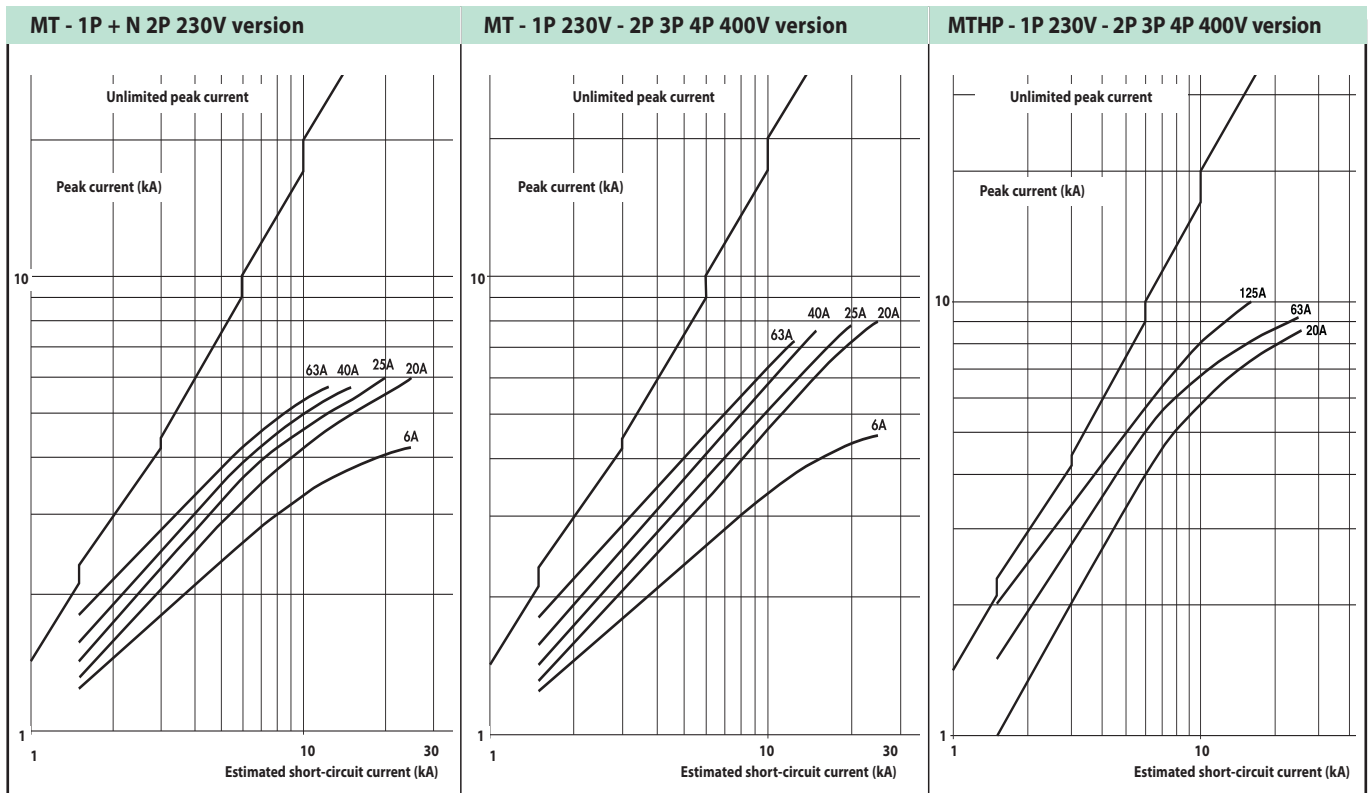
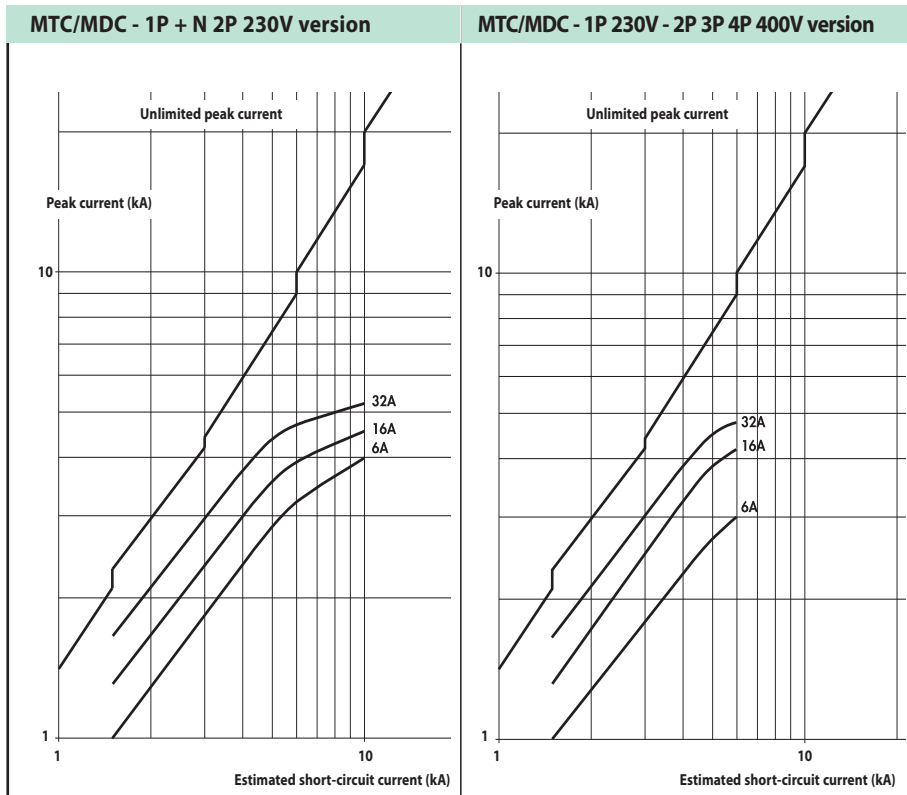

90 MCB RANGE

MODULAR DEVICES FOR CIRCUIT PROTECTION



DIMENSION TABLES

90 MCB RANGE

MTC 45 - MTC 60 - MTC 100

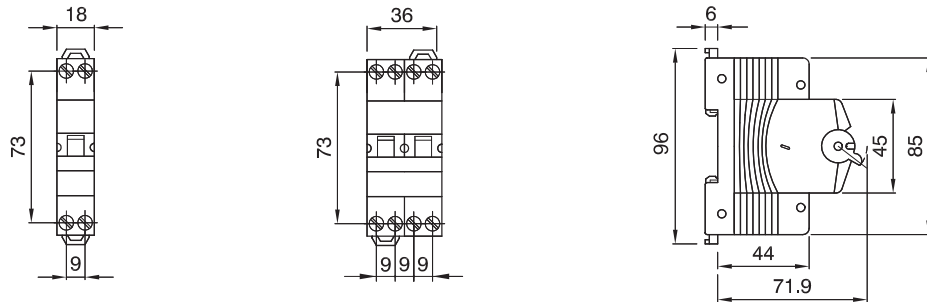

MT 45 - MT 60 - MT 100 - MT 250

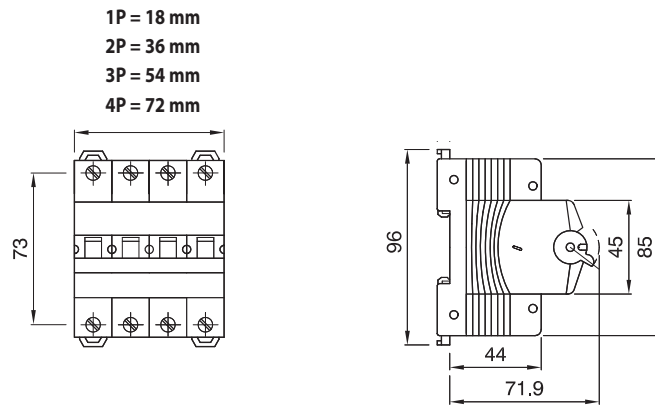

MTHP 160 - MTHP 250

